



**IMPORTANT SAFETY INFORMATION**  
**LETHAL VOLTAGE MAY BE PRESENT**  
**IN ANY PV INSTALLATION**  
**SAVE THESE INSTRUCTIONS**



**WARNING - THIS PHOTOVOLTAIC RAPID SHUTDOWN EQUIPMENT (PVRSE) DOES NOT PERFORM ALL OF THE FUNCTIONS OF A COMPLETE PHOTOVOLTAIC RAPID SHUTDOWN SYSTEM (PVRSS). THIS PVRSE MUST BE INSTALLED WITH OTHER EQUIPMENT TO FORM A COMPLETE PVRSS THAT MEETS THE REQUIREMENTS OF NEC (NFPA 70) SECTION 690.12 FOR CONTROLLED CONDUCTORS OUTSIDE THE ARRAY. OTHER EQUIPMENT INSTALLED IN OR ON THIS PV SYSTEM MAY ADVERSELY AFFECT THE OPERATION OF THE PVRSS. IT IS THE RESPONSIBILITY OF THE INSTALLER TO ENSURE THAT THE COMPLETED PV SYSTEM MEETS THE RAPID SHUTDOWN FUNCTIONAL REQUIREMENTS. THIS EQUIPMENT MUST BE INSTALLED ACCORDING TO THE MANUFACTURER'S INSTALLATION INSTRUCTIONS.**

- To reduce risk of fire and shock hazard, install this device with strict adherence to National Electric Code (NEC) ANSI/NFPA 70 and/or local electrical codes. When the photovoltaic array is exposed to light, it supplies a DC voltage to the Tigo TS4 units and the output voltage may be as high as the PV module open circuit voltage (VOC) when connected to the module. The installer should use the same caution when handling electrical cables from a PV module with or without the TS4 units attached.
- Risk of electric shock: do not disassemble, or repair. There are no user serviceable parts inside. Refer servicing to qualified service personnel.
- Remove all metallic jewelry prior to installing the Tigo TS4 units to reduce the risk of contacting live circuitry. Do not attempt to install in inclement weather.
- Do not operate the Tigo TS4 units if they have been physically damaged. Check existing cables and connectors, ensuring they are in good condition and appropriate in rating. Do not operate Tigo TS4 units with damaged or substandard wiring or connectors. Tigo TS4 units must be mounted on the high end of the PV module backsheet or racking system, and in any case above ground.
- Before installing or using the Tigo System, please read all instructions and warning markings on the Tigo products, appropriate sections of your inverter manual, photovoltaic (PV) module installation manual, and other available safety guides.
- Do not connect or disconnect under load. Turning off the inverter and/or the Tigo products may not reduce this risk. Internal capacitors within the inverter can remain charged for several minutes after disconnecting all power sources. Verify capacitors have discharged by measuring voltage across inverter terminals prior to disconnecting wiring if service is required. Wait 30 seconds after rapid shutdown activation before disconnecting DC cables or turning off DC disconnect.
- When used as a PVRSS solution, all solar modules in the array must be equipped with TS4-A-F/2F and RSS transmitter PVRSE. Rapid shutdown is initiated upon AC power loss that stops power to the RSS transmitter.
- Always connect short input cables before connecting long put output cables. Failure to do so may void warranty.**
- All equipment shall be installed and operated in an environment within the ratings and limitations of the equipment as published in the installation manual.
- Trained professionals must perform installation only. Tigo does not assume liability for loss or damage resulting from improper handling, installation, or misuse of products.
- Disconnect TS4s from the array string before disconnecting from a PV module.
- All TS4 versions ship in the ON state. Use caution when connecting the units to the modules.
- Each TS4 has an IP68 protection rating but only after properly installed.
- Do not leave TS4 connectors exposed to the rain. Water intrusion may damage the TS4.
- Connectors from different manufacturers cannot be mated with each other.
- TS4s must not be installed in readily accessible locations.
- Operating temperature range: -40 – 85 °C (-40 – 185 °F)

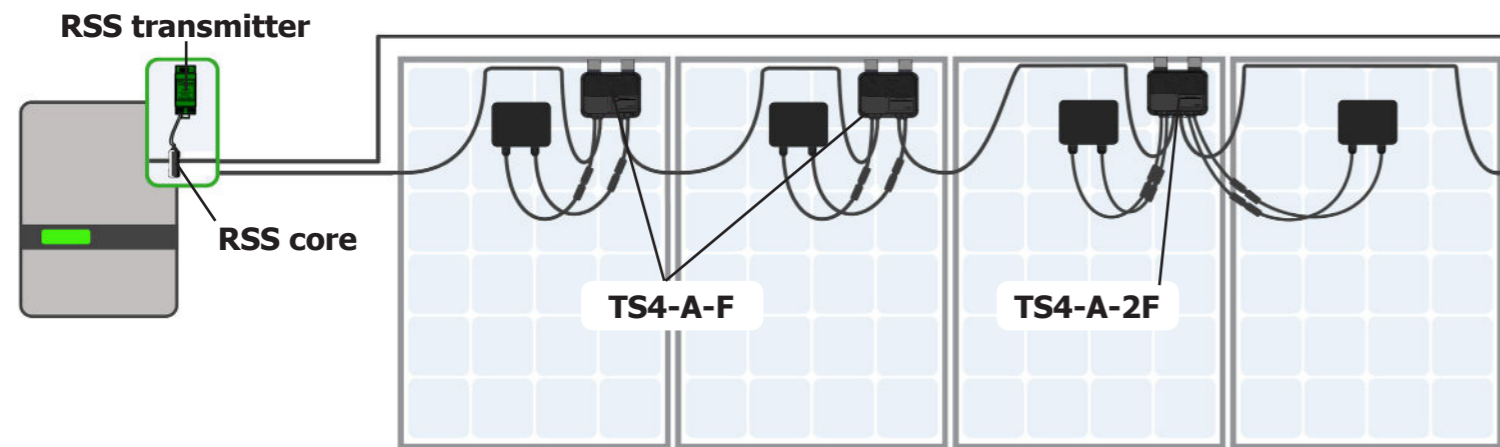

### TS4 Mounting Options

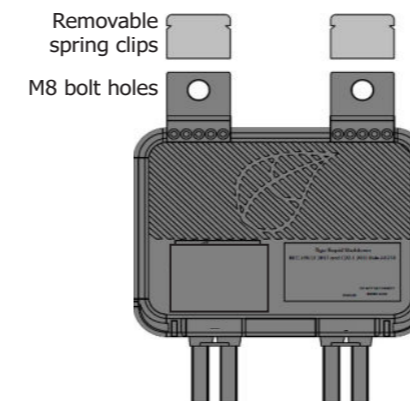

For frameless modules, use M8 bolts torqued to 10.2 Nm.

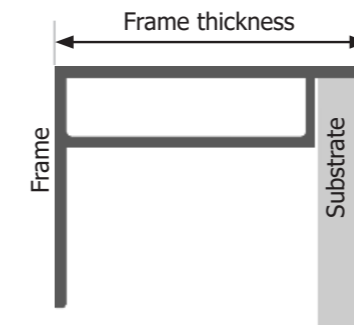

- If frame thickness is  $\leq 35\text{mm}$  (1.4"), install with the TS4 label facing the PV module.
- To enable natural convection (air cooling), no part of the TS4 should be within 12.7 mm (0.5 in) of the module substrate on any side.
- The TS4 ingress rating of TS4 is IP 68.
- Check PV module instructions for restrictions on mounting devices under the module.

### Install TS4-A-Fs

- Connect the short input cables to the PV module.
- Connect the long output leads to the adjacent TS4 to create a string.

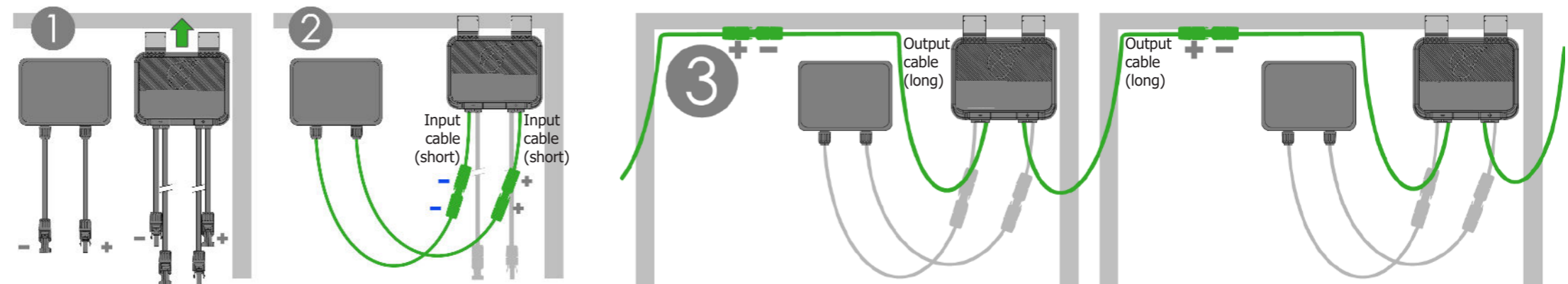

### Install TS4-A-2Fs

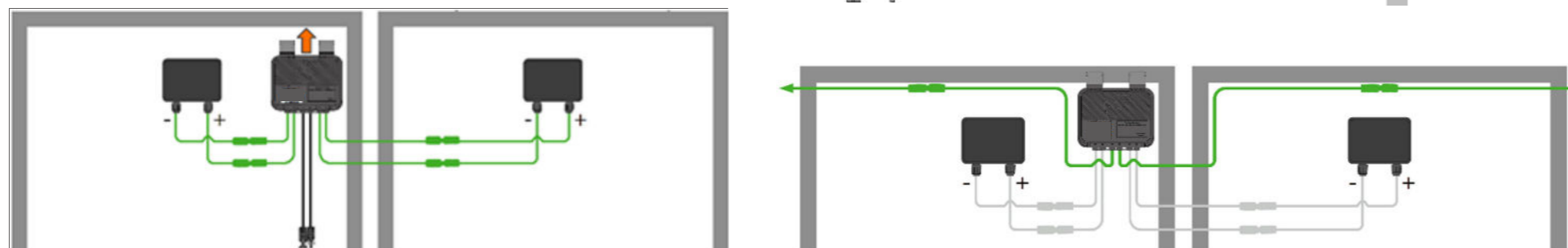

If connecting a TS4-A-2F to only one solar module, connect the TS4 #2 input cables to each other.

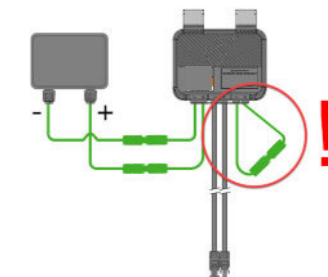



[Download](#) the latest documentation with important updates.

**The RSS Transmitter** Mount on a 35 mm DIN rail within a NEMA 1 (indoors) or NEMA 4 (outdoors) enclosure.

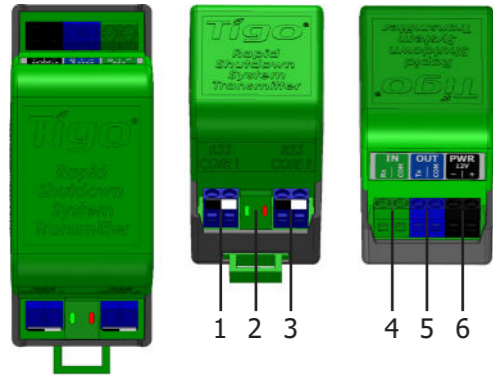

- 1 Core 1 terminals
- 2 Signal status LEDs
- 3 Core 2 terminals
- 4 IN Rx/COM receive terminals
- 5 OUT Rx/COM receive terminals
- 6 Power (- and + 12 V) terminals

- All solar modules in an RSS string must be controlled by a TS4-A-F or TS4-A-2F device. The rapid shutdown system (RSS) controls all conductors.
- This RSS must be connected to an automatic system that initiates rapid shutdown upon the activation of the AC system disconnect. The RSS transmitter must be powered from the same power that the rapid shutdown initiator (RSI) will interrupt in order to trigger a shutdown of the inverter.
- Rapid shutdown occurs within 30 sec. after an AC disconnect (inverter or switch) disconnects AC power to the inverter and RSS transmitter, ceasing transmission of a keep-alive signal.

### Connect a Power Supply

- Transmitters must be on the same AC branch circuit as the inverter.
- Connect one standard, 100-240 V 12 V/1 A power supply per transmitter or connect one commercial, 180-550 V/10 A power supply to up to ten transmitters with parallel connections.

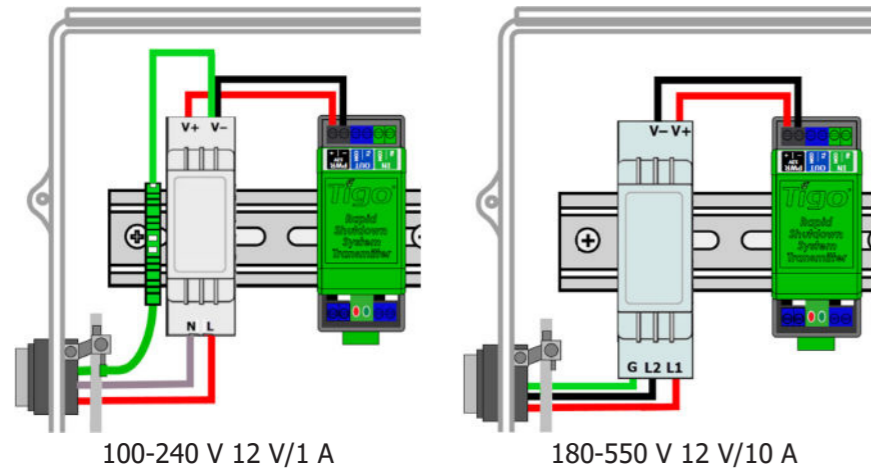

### Connect a Core

- Insert core wires into matching white/black core terminals.
- Route up to ten negative PV conductors through a core.
- The white side of the core must face the inverter.
- Maximum home run length is 300 m (985 ft.).

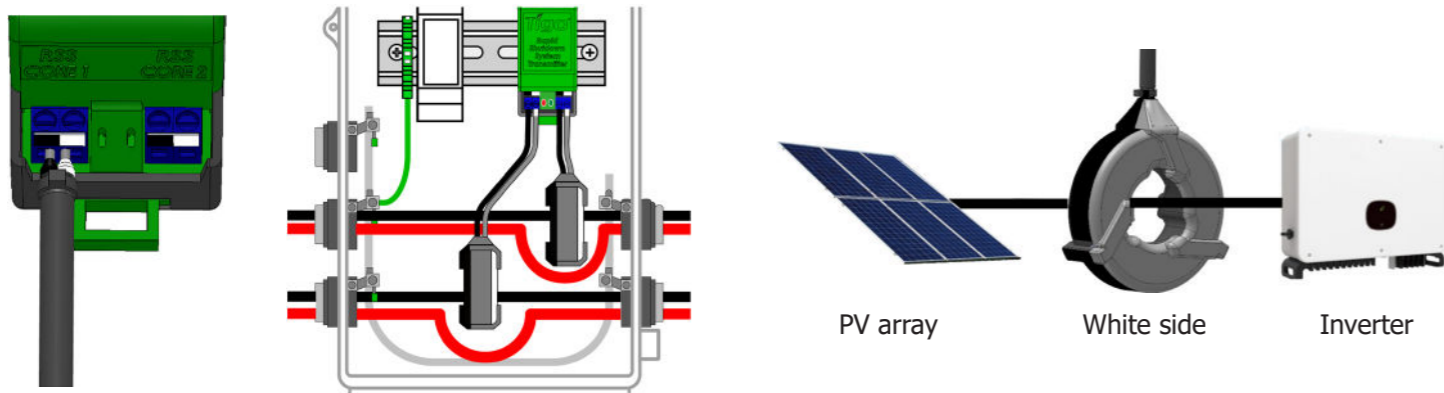

### Connect Signal Wiring

**The total length of signal wire from the first to the last transmitter should not exceed 100 feet.**

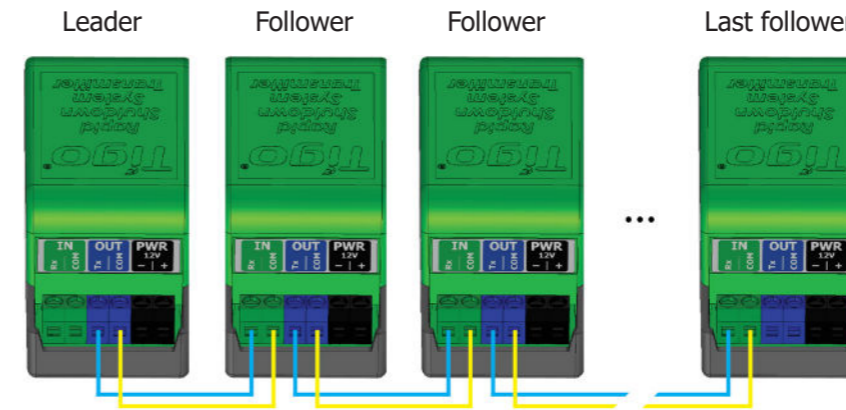

- Connect 14 – 22 AWG wires between OUT/ Tx and IN/Rx terminals and between OUT/ COM and IN/COM terminals.
- Check that Tx/Rx wires never contact COM terminals.

If connected correctly:

- The leader transmitter displays a continuous red LED and a blinking green LED.
- Follower transmitter LEDs blink green simultaneously with no red.

### Specifications and Additional PVRSS UL 1741 Compliance Information

Model	Max. Power	Max. Input V	Max. Input I <sub>MP</sub>	Max. Input I <sub>SC</sub>	Max. System V <sup>1</sup>
TS4-A-F 15 A	700 W	80 V	15 A	15 A	1000/1500 V
TS4-A-F 25 A	700 W	80 V	20 A	25 A	1000/1500 V
TS4-A-2F 15 A	1000 W	80 V	15 A	15 A	1000/1500 V
TS4-A-2F 25 A	1400 W	80 V	20 A	25 A	1000/1500 V

<sup>1</sup> Depending on connection method.

- Caution: Risk of fire and shock hazard. Device(s) must be protected at system level (PV string) with PV fuse rated maximum 20 A, minimum voltage rating based on system voltage, 600 V<sub>DC</sub>, 1000 V<sub>DC</sub> or 1500V<sub>DC</sub>.
- TS4-A-F/2F PV array (DC) conductors are 12 AWG.
- Normal operating temperature range is -30 °C to 70 °C.
- TS4-A-F/2Fs are compatible with the grid support function described in UL 1741 Tables SA9.1 and SA10.1: response to low- and high-voltage ride-through (L/HVRT) and low- and high-frequency ride-through (L/HFRT) requirements.
- Connectors from different manufacturers cannot be mated with each other.
- Modules must not be installed in readily accessible locations (Canada only).

WARNING – THIS PHOTOVOLTAIC RAPID SHUTDOWN EQUIPMENT (PVRSE) DOES NOT PERFORM ALL OF THE FUNCTIONS OF A COMPLETE PHOTOVOLTAIC RAPID SHUTDOWN SYSTEM (PVRSS). THIS PVRSE MUST BE INSTALLED WITH OTHER EQUIPMENT TO FORM A COMPLETE PVRSS THAT MEETS THE REQUIREMENTS OF NEC (NFPA 70) SECTION 690.12 FOR CONTROLLED CONDUCTORS OUTSIDE THE ARRAY. OTHER EQUIPMENT INSTALLED IN OR ON THIS PV SYSTEM MAY ADVERSELY AFFECT THE OPERATION OF THE PVRSS. IT IS THE RESPONSIBILITY OF THE INSTALLER TO ENSURE THAT THE COMPLETED PV SYSTEM MEETS THE RAPID SHUT DOWN FUNCTIONAL REQUIREMENTS. THIS EQUIPMENT MUST BE INSTALLED ACCORDING TO THE MANUFACTURER'S INSTALLATION INSTRUCTIONS.

In accordance with Section 690.56(C) of the NEC (NFPA 70), a rapid shutdown system label must be placed no more than 1 m (3 ft.) from the initiator (AC disconnect) or service panel containing a means of disconnection if not at the same location.

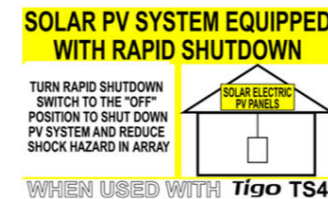

### Resources



002-00157-00 Rev. 1.3