



ALL IN ONE ESS

GB-SL5K-EU

GB-SL6K-EU

GB-SL8K-EU

GB-SL10K-EU

GB-SL12K-EU

GB-SL15K-EU

GB-SL20K-EU

User Manual

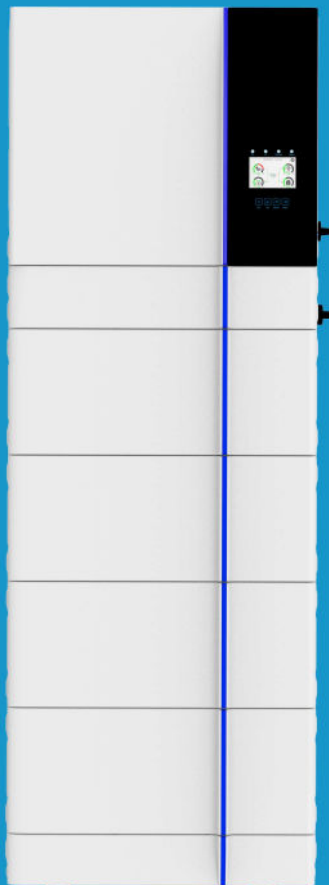

Contents

1. Safety Introductions	01
2. Product instructions	01-05
2.1 Product Overview	
2.2 Product Size	
2.3 Product Features	
2.4 Basic System Architecture	
3. Installation	05-26
3.1 Parts list	
3.2 Mounting instructions	
3.3 Battery connection	
3.4 Grid connection and backup load connection	
3.5 PV Connection	
3.6 CT Connection	
3.6.1 Meter Connection	
3.7 Earth Connection(mandatory)	
3.8 WIFI Connection	
3.9 Wiring System for Inverter	
3.10 Wiring diagram	
3.11 Typical application diagram of diesel generator	
3.12 phase parallel connection diagram	
4. OPERATION	27-28
4.1 Power ON/OFF	
4.2 Operation and Display Panel	
5. LCD Display Icons	28-40
5.1 Main Screen	
5.2 Solar Power Curve	
5.3 Curve Page-Solar & Load & Grid	
5.4 System Setup Menu	
5.5 Basic Setup Menu	
5.6 Battery Setup Menu	
5.7 System Work Mode Setup Menu	
5.8 Grid Setup Menu	
5.9 Generator Port Use Setup Menu	
5.10 Advanced Function Setup Menu	
5.11 Device Info Setup Menu	
6. Mode	40-41
7. Limitation of Liability	41-45
8. Datasheet	46-47
9. Appendix I	48-49
10. Appendix II	50

About This Manual

The manual mainly describes the product information, guidelines for installation, operation and maintenance. The manual cannot include complete information about the photovoltaic (PV) system.

How to Use This Manual

Read the manual and other related documents before performing any operation on the inverter. Documents must be stored carefully and be available at all times.

Contents may be periodically updated or revised due to product development. The information in this manual is subject to change without notice. The latest manual can be acquired via service@deye.com.cn

1. Safety Introductions

- This chapter contains important safety and operating instructions. Read and keep this manual for future reference.
- Before using the inverter, please read the instructions and warning signs of the battery and corresponding sections in the instruction manual.
- Do not disassemble the inverter. If you need maintenance or repair, take it to a professional service center.
- Improper reassembly may result in electric shock or fire.
- To reduce risk of electric shock, disconnect all wires before attempting any maintenance or cleaning. Turning off the unit will not reduce this risk.
- Caution: Only qualified personnel can install this device with battery.
- Never charge a frozen battery.
- For optimum operation of this inverter, please follow required specification to select appropriate cable size. It is very important to correctly operate this inverter.
- Be very cautious when working with metal tools on or around batteries. Dropping a tool may cause a spark or short circuit in batteries or other electrical parts, even cause an explosion.
- Please strictly follow installation procedure when you want to disconnect AC or DC terminals. Please refer to "Installation" section of this manual for the details.
- Grounding instructions - this inverter should be connected to a permanent grounded wiring system. Be sure to comply with local requirements and regulation to install this inverter.
- Never cause AC output and DC input short circuited. Do not connect to the mains when DC input short circuits.

2. Product Introduction

This is a multifunctional inverter, combining functions of inverter, solar charger and battery charger to offer uninterruptible power support with portable size. Its comprehensive LCD display offers user configurable and easy accessible button operation such as battery charging, AC/solar charging, and acceptable input voltage based on different applications.

2.1 Product Overview

Inverter

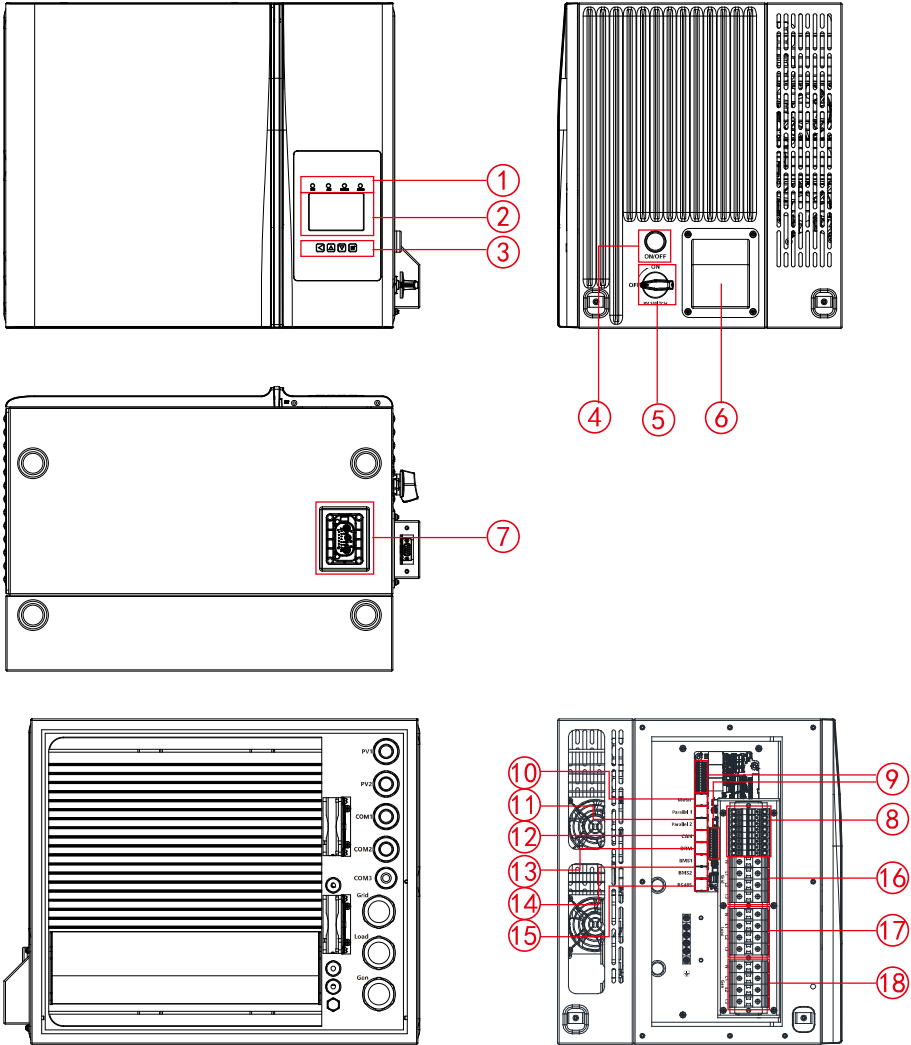

1: Inverter indicators

2: LCD display

3: Function buttons

4: Power on/off button

5: DC switch

6: WiFi Interface

7: Battery input connectors

8: PV input

9: Function port

10: Meter port

11: Parallel port

12: CAN port

13: DRM port

14: BMS port

15: RS485 port

16: Grid

17: Load

18: Generator input

High Voltage Control Box

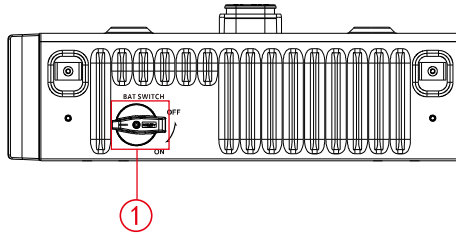

1: High Voltage DC switch

2.2 Product Size

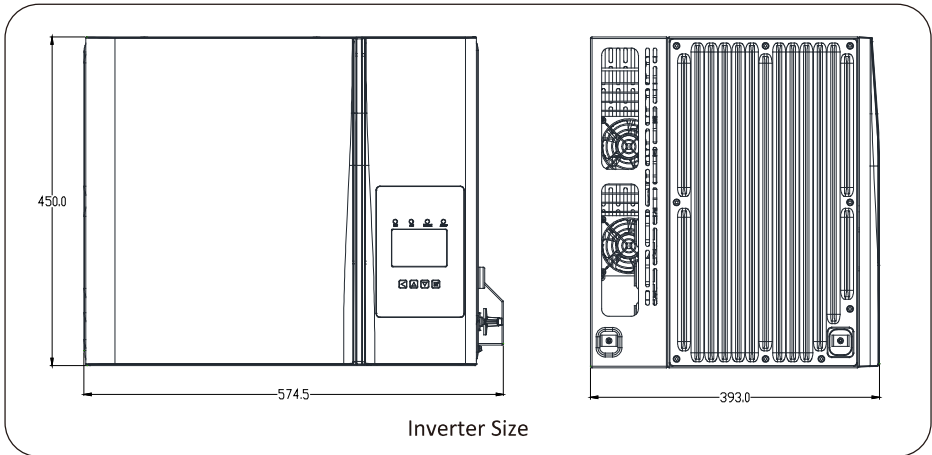

Inverter Size

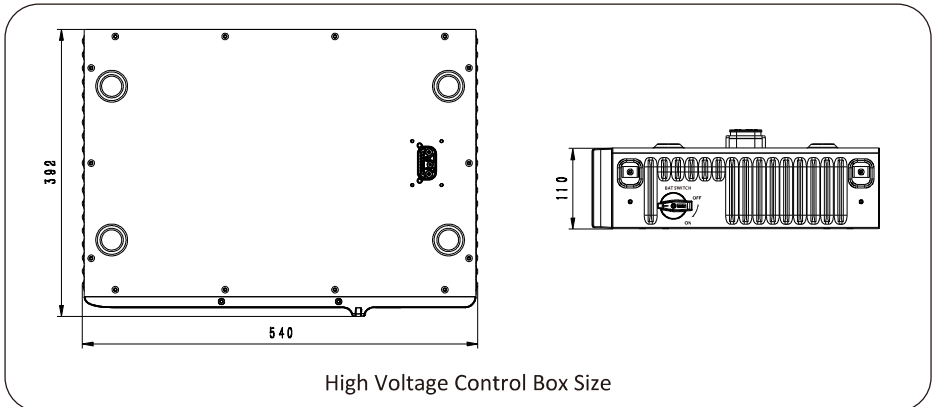

High Voltage Control Box Size

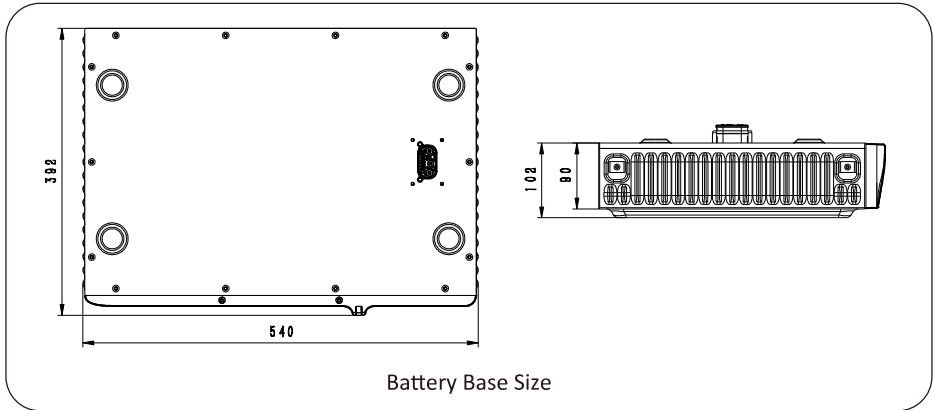
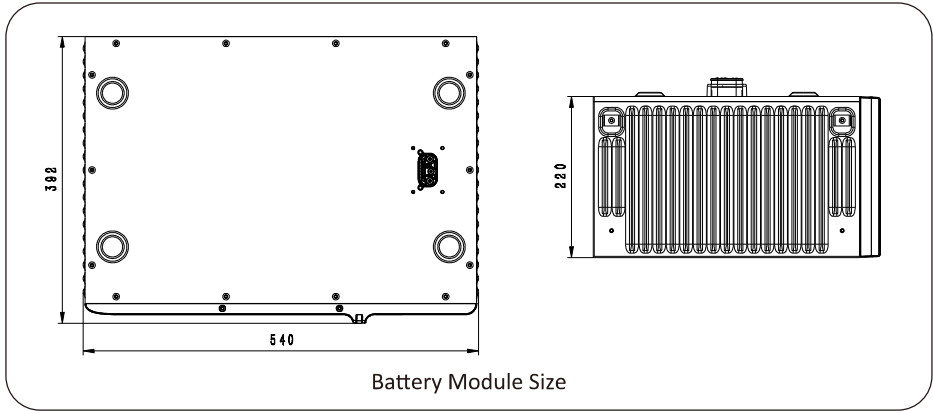

2.3 Product Features

- 230V/400V Three phase Pure sine wave inverter.
- Self-consumption and feed-in to the grid.
- Auto restart while AC is recovering.
- Programmable supply priority for battery or grid.
- Programmable multiple operation modes: On grid, off grid and UPS.
- Configurable battery charging current/voltage based on applications by LCD setting.
- Configurable AC/Solar/Generator Charger priority by LCD setting.
- Compatible with mains voltage or generator power.
- Overload/over temperature/short circuit protection.
- Smart battery charger design for optimized battery performance
- With limit function, prevent excess power overflow to the grid.
- Supporting WIFI monitoring and build-in 2 strings for 1 MPP tracker, 1 string for 1 MPP tracker.
- Smart settable three stages MPPT charging for optimized battery performance.
- Time of use function.
- Smart Load Function.

2.4 Basic System Architecture

The following illustration shows basic application of this inverter. It also includes following devices to have a complete running system.

- Generator or Utility
- PV modules

Consult with your system integrator for other possible system architectures depending on your requirements.

This inverter can power all kinds of appliances in home or office environment, including motor type appliances such as refrigerator and air conditioner.

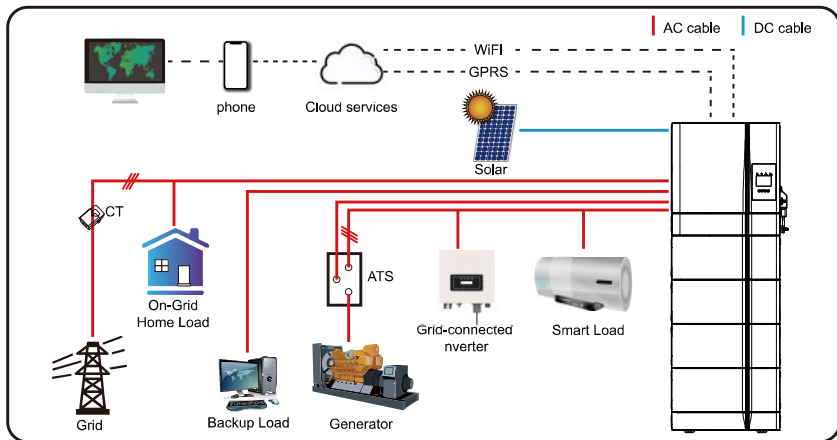

3. Installation

3.1 Parts List

Check the equipment before installation. Please make sure nothing is damaged in the package. You should have received the items in the following package:

Inverter package

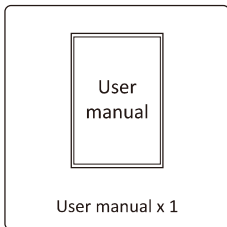
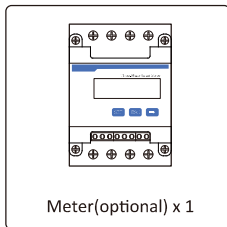
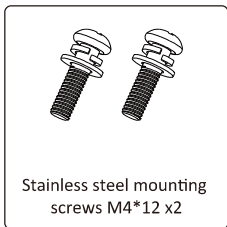
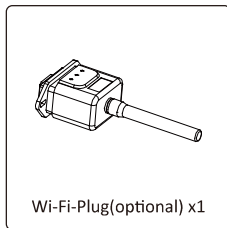
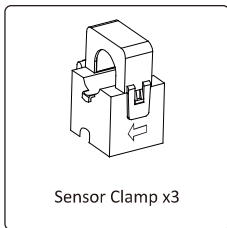
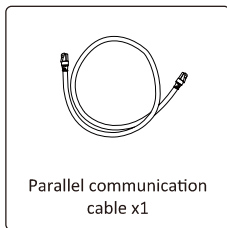
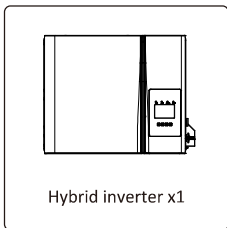

GB-LBS and GB-L Base package

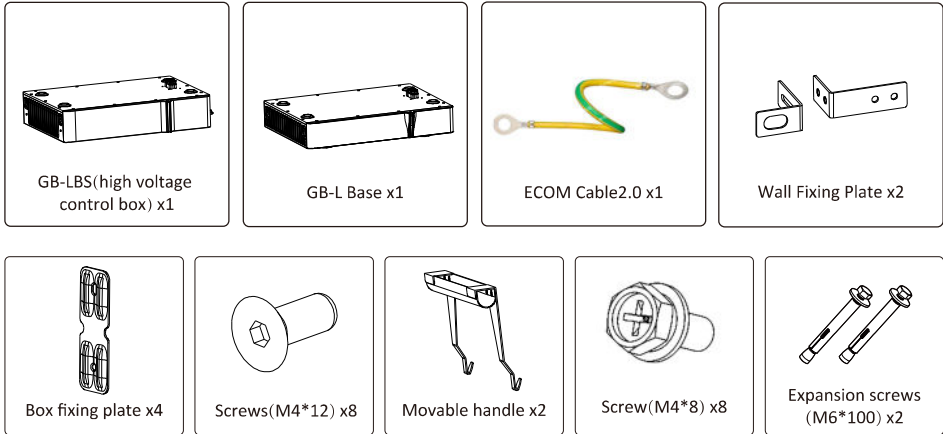

GB-LM4.0 battery package

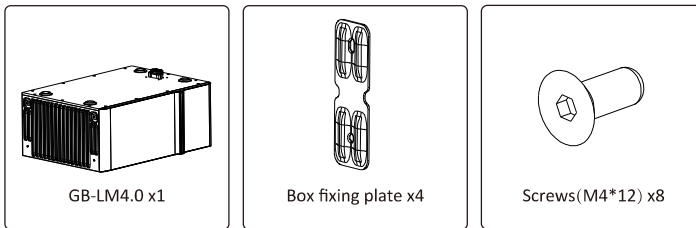

3.2 Mounting instructions

Installation Precaution

This Hybrid inverter is designed for outdoor use (IP65), Please make sure the installation site meets below conditions:

- Not in direct sunlight
- Not in areas where highly flammable materials are stored.
- Not in potential explosive areas.
- Not in the cool air directly.
- Not near the television Antenna or antenna cable.
- Not higher than altitude of about 2000 meters above sea level.
- Not in environment of precipitation or humidity (>95%)

Please AVOID direct sunlight, rain exposure, snow laying up during installation and operation. Before connecting all wires, please take off the metal cover by removing screws as shown below:

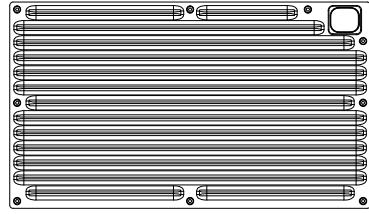
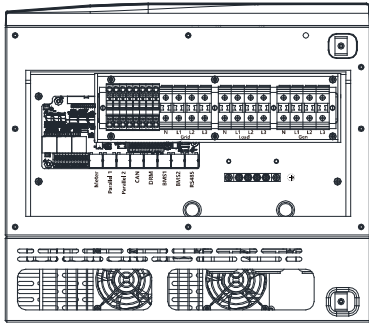

3.3 Battery connection

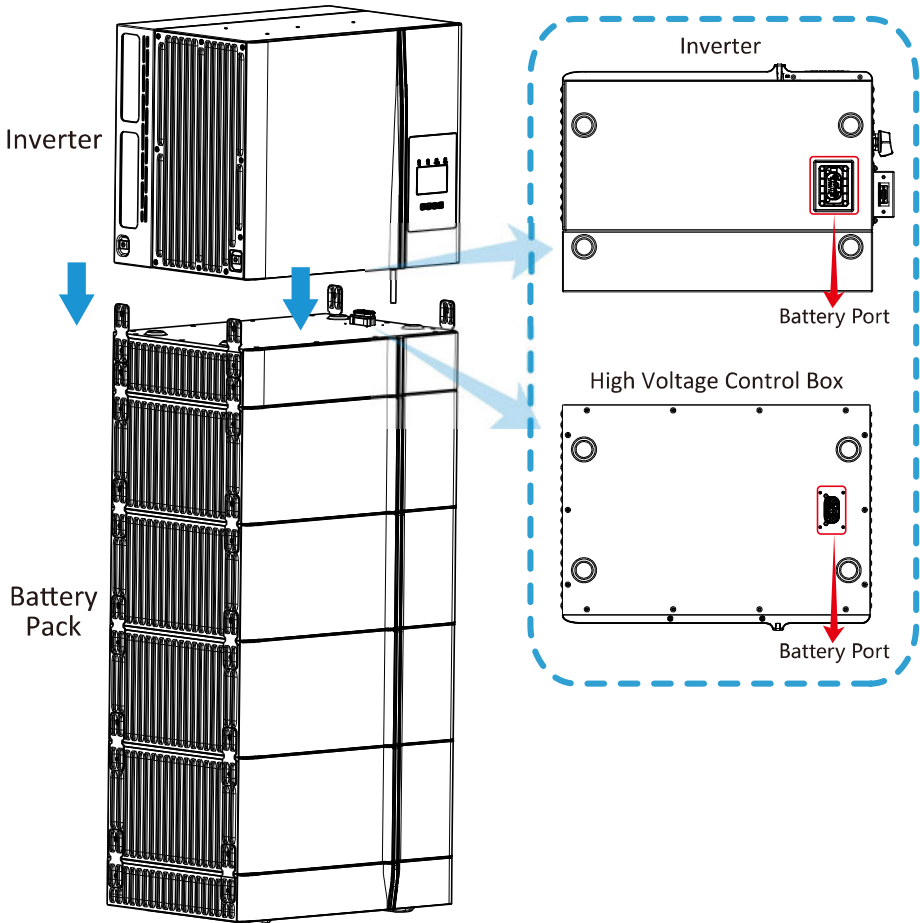

3.3.1 Install the Battery

Installation Place Requirement

- Installed on the surface with enough dryness, horizontal and flat, and has sufficient carrying capacity. (For example, concrete or masonry).
- The altitude of the installation location must not be higher than 2000 meters. (The output power of the battery will decrease with the height of the altitude).
- If in the flood area, you must pay attention to ensure that the battery is installed in an appropriate altitude and prevent contact with water.
- Ensure there is no fire source, and it must be equipped with an independent fire alarm device.
- Cannot be exposed to corrosive environments.
- The working temperature range should be -20 C to Max.+60 C .
- The maximum environment humidity is 90%.
- Can't be exposed to the sun or beside the heat source directly.
- The installation site must be away from the children and the old.
- The installation position must be compatible with the weight and size of the battery.

Tools Requirements

When installing the battery system, wear the following safety equipment :



Gloves



Goggles



Safety Shoes

When installing the battery system, prepare the following spare parts :



Socket Head Wrench



External Hexagonal wrench



Electric Drill

Attention:

- Because the DC cable or connector on the battery system may cause electric shock or very dangerous life, do not contact the end of the non-insulating cable.
- If the battery module incorrectly lifts or falls in the process of transportation or installation, it may cause the risk of injury due to the weight of the battery module.
- Carefully transport and lift the battery module. Consider the weight of the battery module.
- For those who work for the battery system, please wear qualified personal protection equipment.

Note: Before the battery is installed, please switch off the Air Switch of the high Voltage Control Box.

Note: Wear gloves, goggles and safety shoes before installation.

Installation steps



CAUTION!

- Before installation, please make sure to wear the safety shoes to prevent foot injury.
- The weight of a battery module over 30kg. Use the movable handle tool, and two people should work together to move it.
- Do not use the movable handle tool to carry the battery module when the distance is $\geq 10\text{m}$.
- Before using the transport tools, check whether they are reliable.
- The installation humidity ranges from 5% to 90%.

1. Take out the base and battery module. Place the base on hard floor, lift the battery module on top of the base using a movable handle tool.

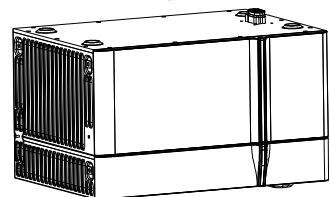
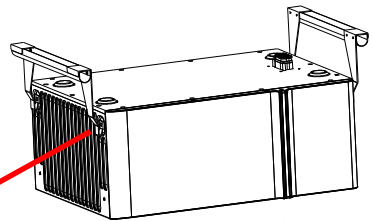
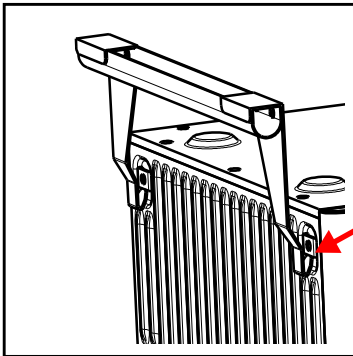

After the battery module is connected to the base, the battery module plug-in port is electriferous. Take good insulation protection, pay attention to high voltage dangers and shot circuit dangers!

2. Stack the corresponding connection ports at the bottom of the battery module. The number of stackable battery modules for a single battery system ranges from 2 to 6.

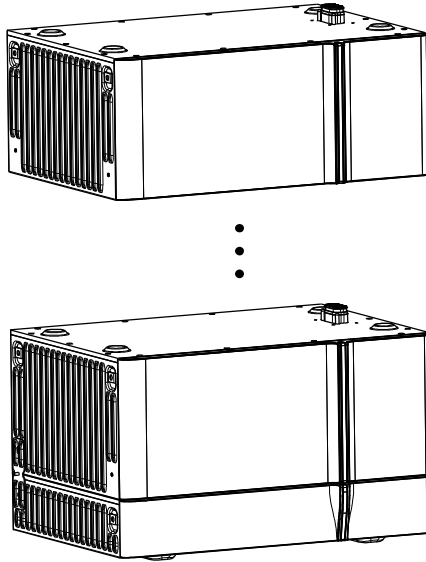

3. Take out the high voltage box, and install the wall fixing plate on the pre-mounting hole of the high voltage box with M4*8 screws.

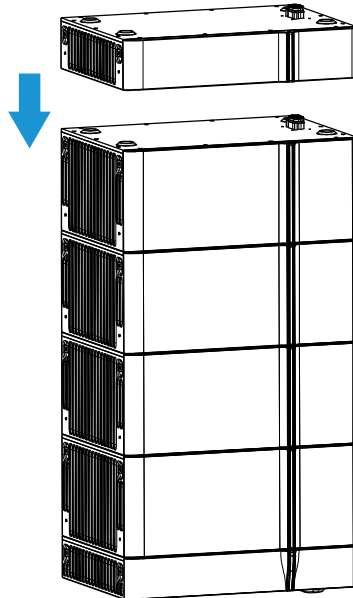

4. Finally, install the high voltage box to the top layer of the battery module.

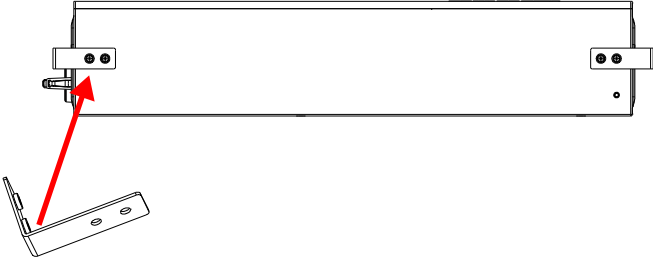

5. Use M4*12 hex socket screws to install the box fixing plate between the base and the battery module, between the battery modules, between the battery module and the high voltage box as well.

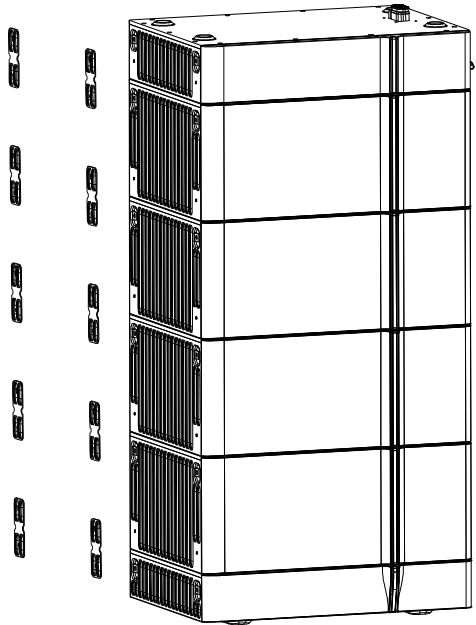
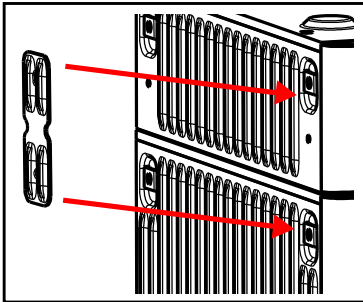

6. Place the high voltage box on one side of the wall, mark the positions of fixing holes, drill two holes in the wall with a depth of 100-110mm using the electrical drill, secure the high voltage box to the wall and install expansion bolts in the holes with a proper hammer.

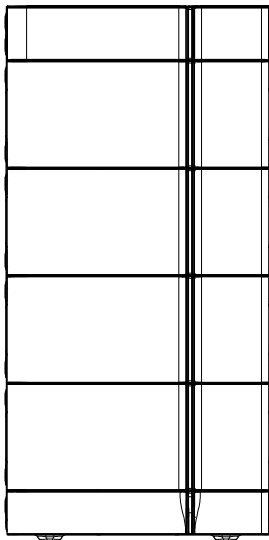

Selection of installation sites

The installation location is recommended to meet the size requirements of the figure below:

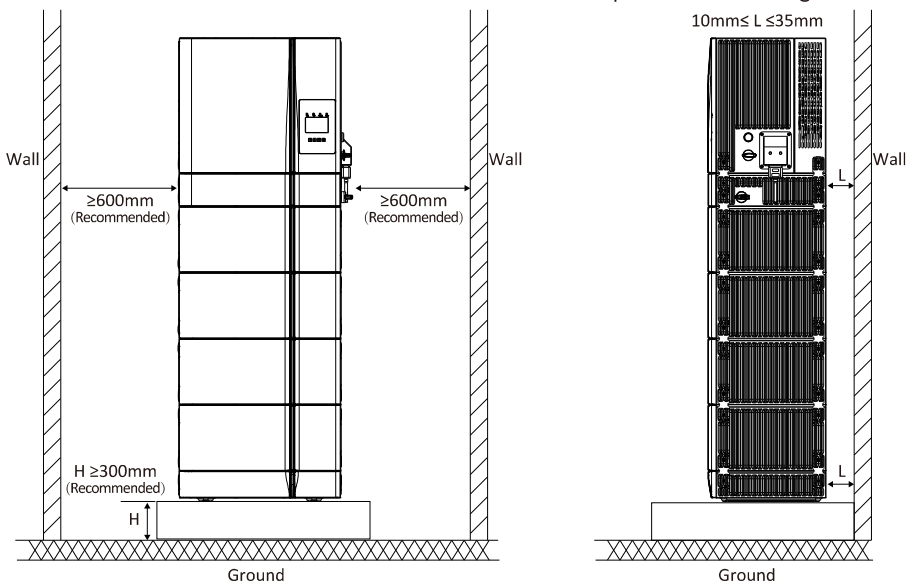

3.3.2 Function port definition

Inverter

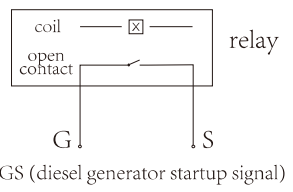
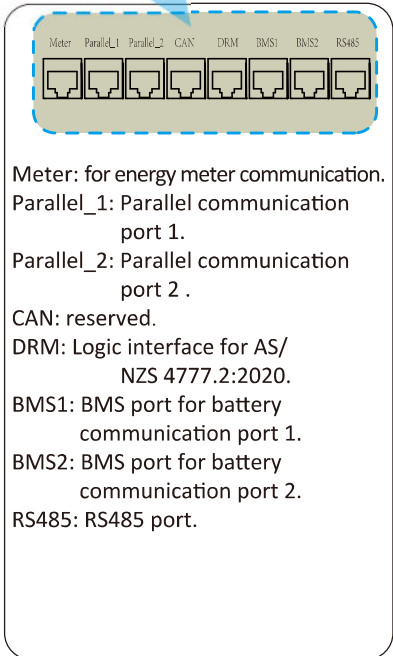
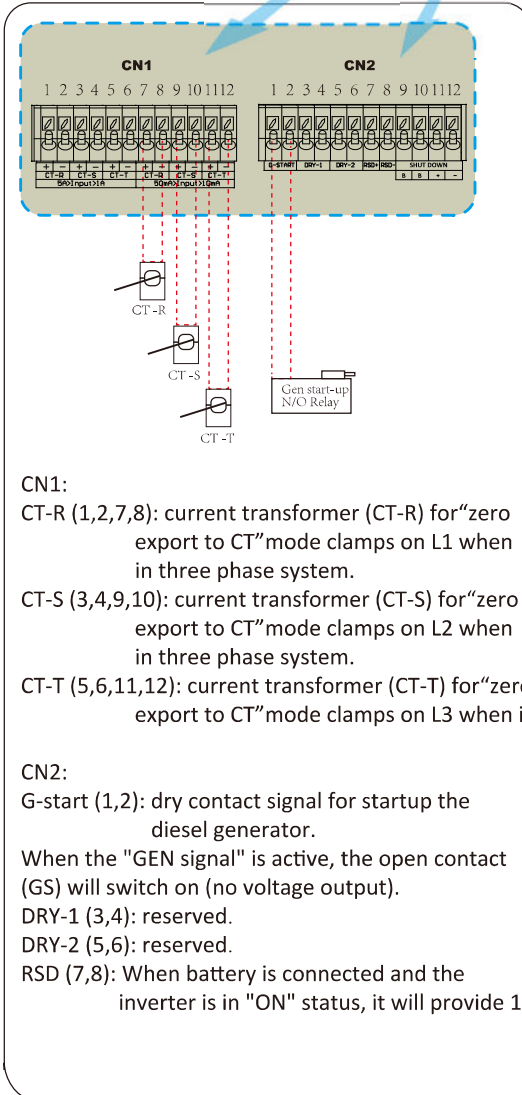
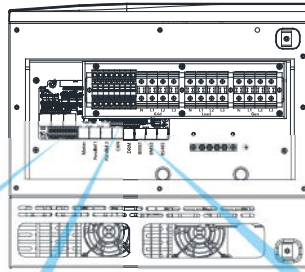

3.4 Grid connection and backup load connection

- Before connecting to grid, please install a separate AC breaker between inverter and grid. Also, it is recommended that installs an AC breaker between backup load and inverter. This will ensure the inverter can be securely disconnected during maintenance and fully protected from over current. For the 5/6/8/10/12/15/20KW model, the recommended AC breaker for backup load is 100A. For the 5/6/8/10/12/15/20KW model, the recommended AC breaker for grid is 100A.
- There are three terminal blocks with "Grid" "Load" and "GEN" markings. Please do not misconnect input and output connectors.



All wiring must be performed by a qualified personnel. It is very important for system safety and efficient operation to use appropriate cable for AC input connection. To reduce risk of injury, please use the proper recommended cable as below.

backup load connection

Model	Wire Size	Cable(mm ²)	Torque value(max)
5/6/8/10Kw	8AWG	10	2.5Nm
12/15/20Kw	4AWG	25	2.5Nm

Grid connection

Model	Wire Size	Cable(mm ²)	Torque value(max)
5/6/8/10Kw	8AWG	10	2.5Nm
12/15/20Kw	4AWG	25	2.5Nm

Chart 3-3 Recommended Size for AC wires

Please follow below steps to implement Grid, load and Gen port connection:

1. Before making Grid, load and Gen port connection, be sure to turn off AC breaker or disconnecter first.
2. Remove insulation sleeve 10mm length, insert the wires according to polarities indicated on the terminal block. Make sure the connection is complete.

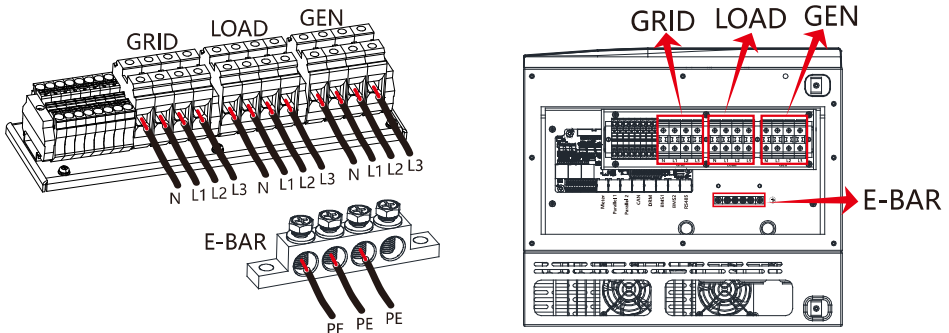



Be sure that AC power source is disconnected before attempting to wire it to the unit.

3. Then, insert AC output wires according to polarities indicated on the terminal block and tighten terminal. Be sure to connect corresponding N wires and PE wires to related terminals as well.
4. Make sure the wires are securely connected.
5. Appliances such as air conditioner are required at least 2-3 minutes to restart because it is required to have enough time to balance refrigerant gas inside of circuit. If a power shortage occurs and recovers in short time, it will cause damage to your connected appliances. To prevent this kind of damage, please check manufacturer of air conditioner if it is equipped with time-delay function before installation. Otherwise, this inverter will trigger overload fault and cut off output to protect your appliance but sometimes it still causes internal damage to the air conditioner

3.5 PV Connection

Before connecting to PV modules, please install a separately DC circuit breaker between inverter and PV modules. It is very important for system safety and efficient operation to use appropriate cable for PV module connection.



To avoid any malfunction, do not connect any PV modules with possible leakage current to the inverter. For example, grounded PV modules will cause leakage current to the inverter. When using PV modules, please ensure the PV+ & PV- of solar panel is not connected to the system ground bar.



It is requested to use PV junction box with surge protection. Otherwise, it will cause damage on inverter when lightning occurs on PV modules.

Cable type	Cross section (mm ²)	
	Range	Recommended value
Industry generic PV cable (model: PV1-F)	2.5-6 (12~9AWG)	4(11AWG)

Chart 3-4



Safety Hint:

Please use approved DC cable for PV system.

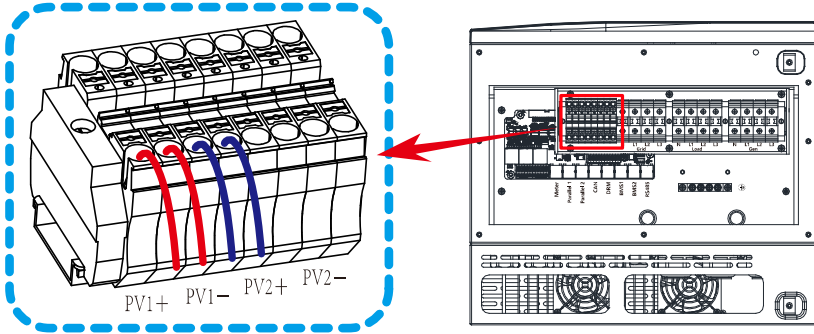

3.5.1 PV Module Selection:

When selecting proper PV modules, please be sure to consider below parameters:

- 1) Open circuit Voltage (Voc) of PV modules can not exceed max. PV array open circuit voltage of inverter.
- 2) Open circuit Voltage (Voc) of PV modules should be higher than min. start voltage.
- 3) The PV modules used to connected to this inverter shall be Class A rating certified according to IEC 61730.

<i>Inverter Model</i>	<i>5KW</i>	<i>6KW</i>	<i>8KW</i>	<i>10KW</i>	<i>12KW</i>	<i>15KW</i>	<i>20KW</i>
PV Input Voltage	600V (180V~1000V)						
PV Array MPPT Voltage Range	150V-850V						
No. of MPP Trackers	2						
No. of Strings per MPP Tracker	1+1					2+1	2+2

Chart 3-5

3.6 CT Connection

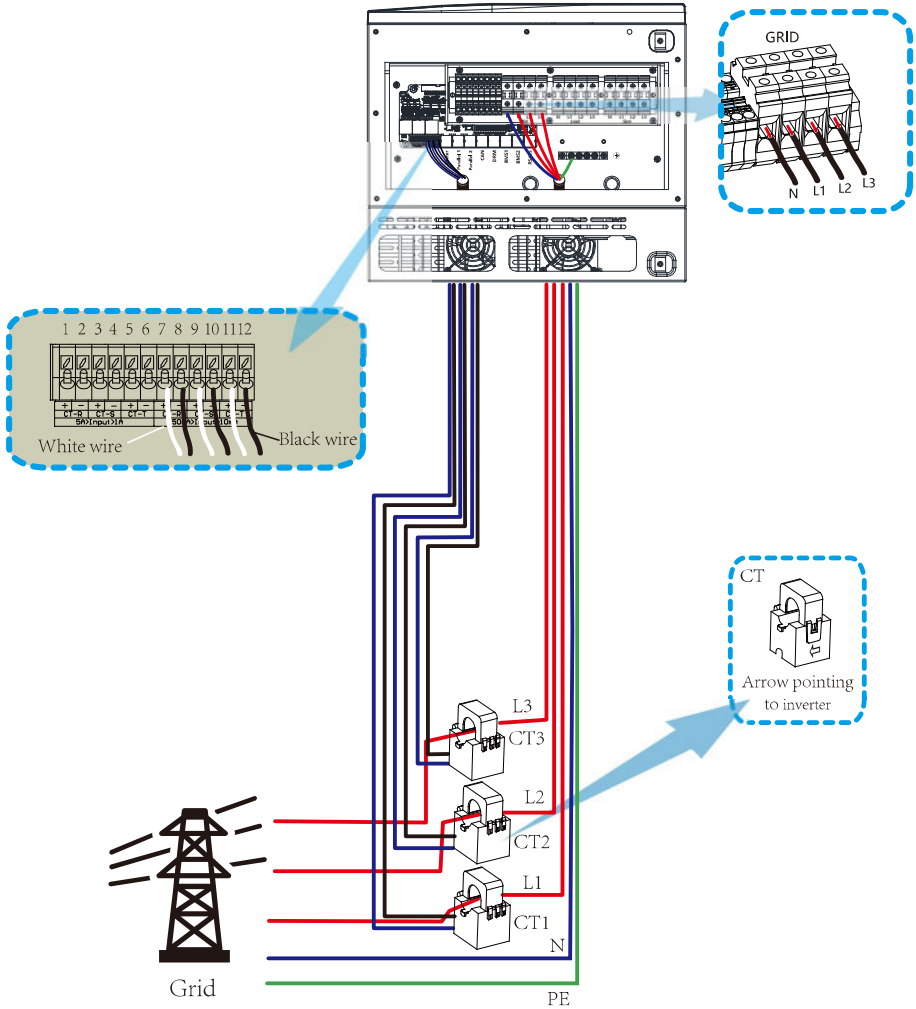

***Note:** when the reading of the load power on the LCD is not correct, please reverse the CT arrow.

3.6.1 Meter Connection

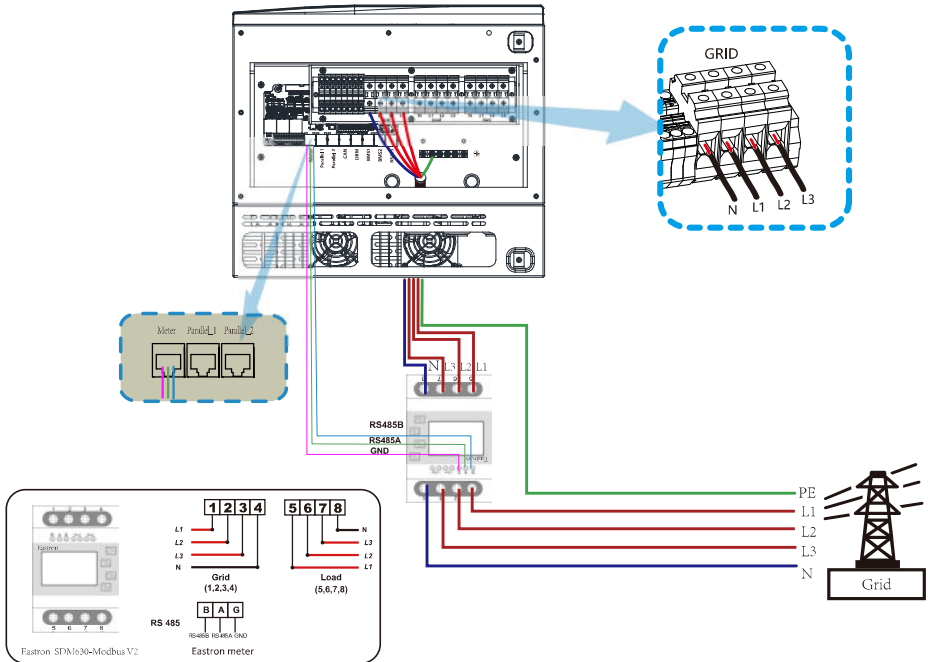
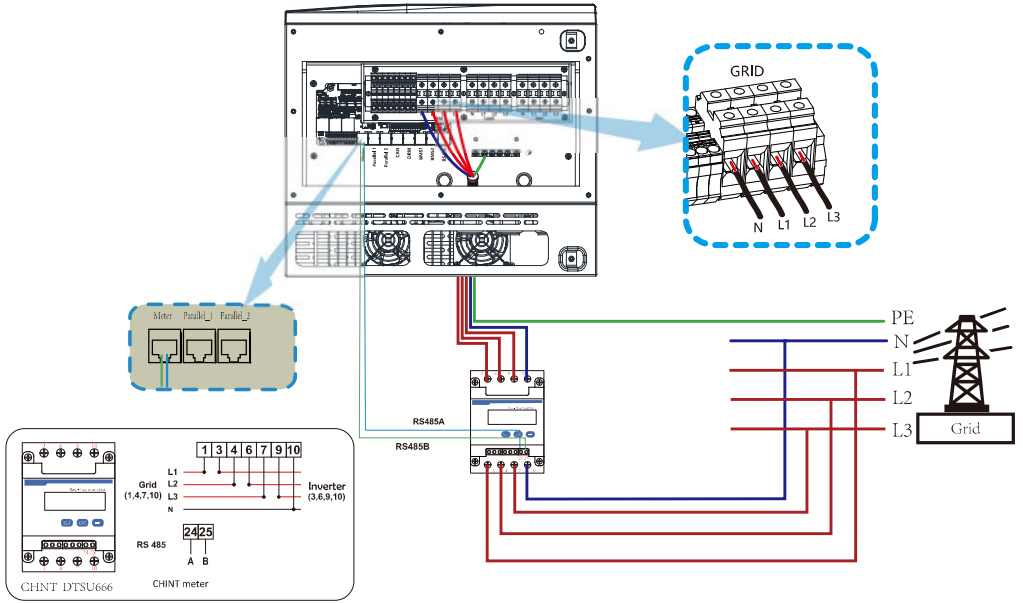

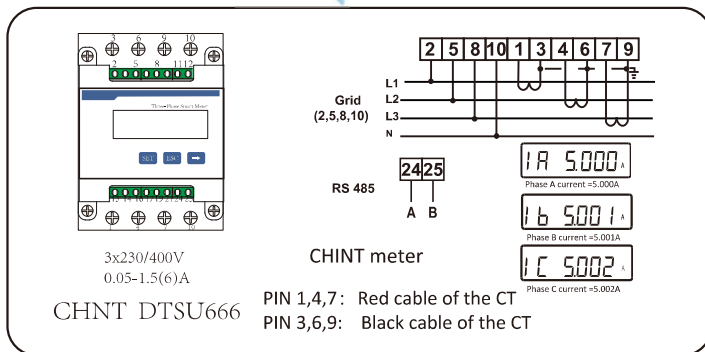
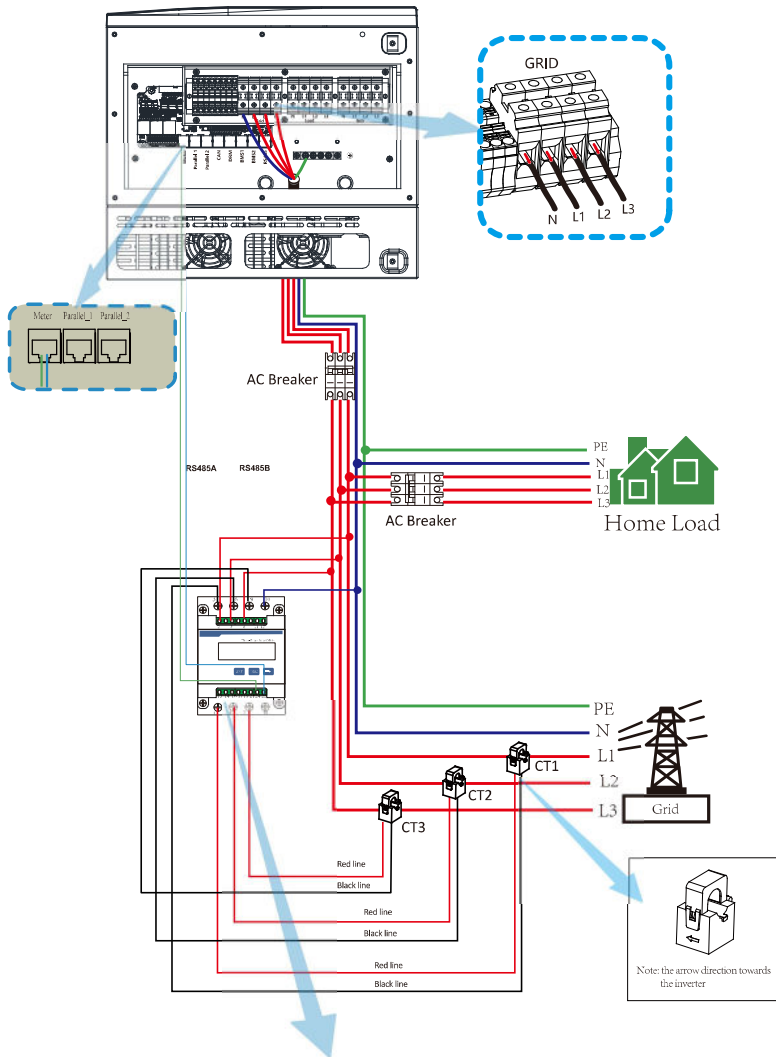

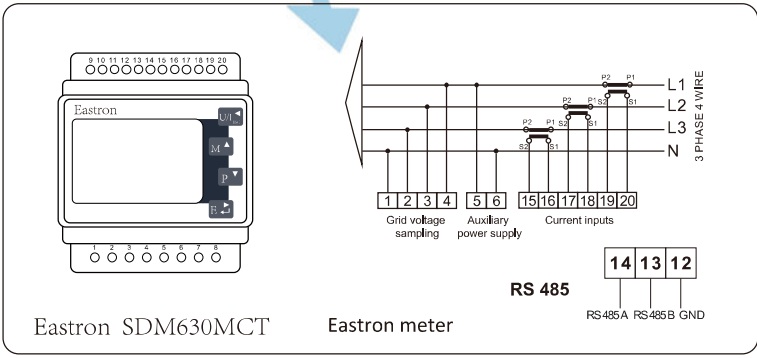
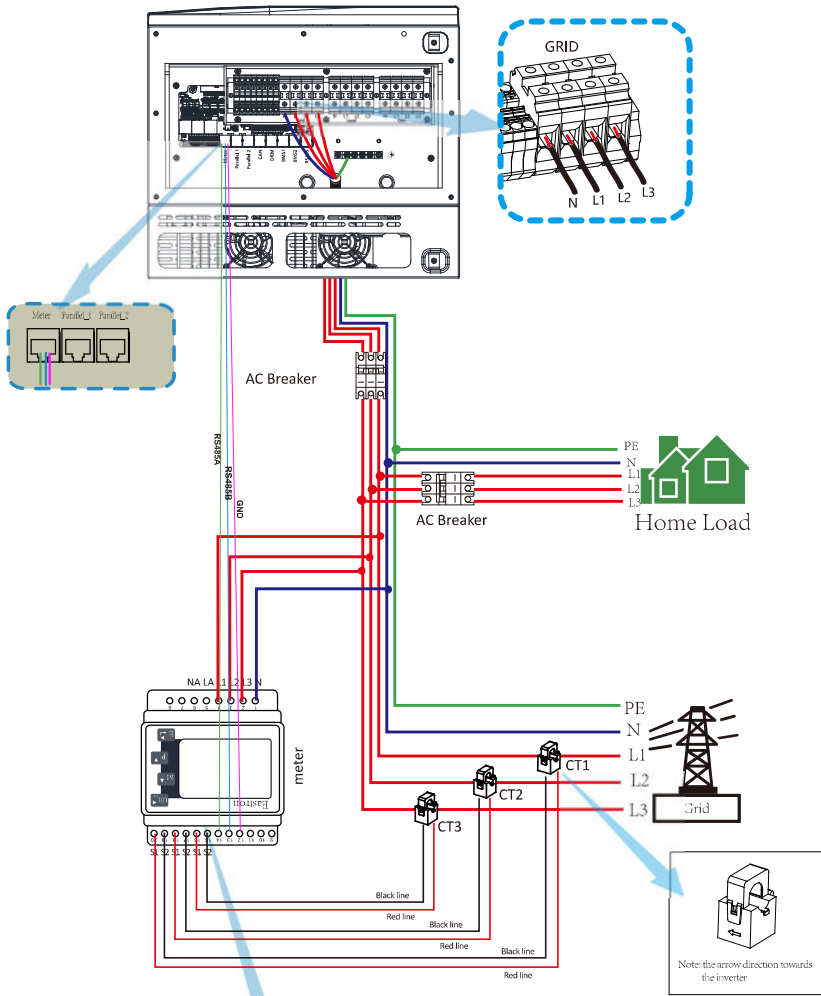



Note:

When the inverter is in the off-grid state, the N line needs to be connected to the earth.



Note:

In final installation, breaker certified according to IEC 60947-1 and IEC 60947-2 shall be installed with the equipment.

3.7 Earth Connection(mandatory)

Ground cable shall be connected to ground plate on grid side this prevents electric shock if the original protective conductor fails.

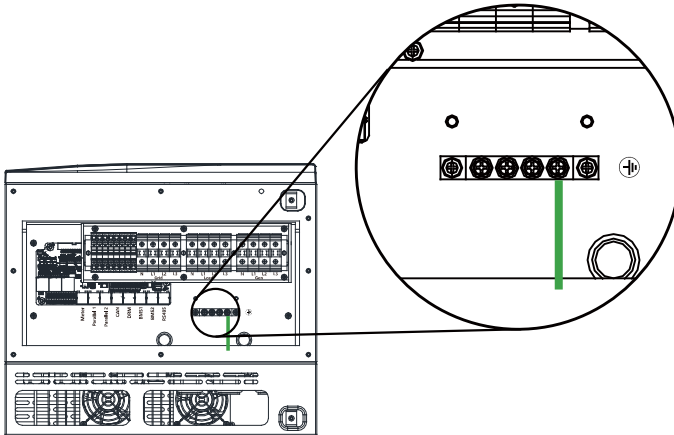

3.8 WIFI Connection

For the configuration of Wi-Fi Plug, please refer to illustrations of the Wi-Fi Plug. The Wi-Fi Plug is not a standard configuration, it's optional.

3.9 Wiring System for Inverter

This diagram is an example for an application that neutral connects with the PE in a distribution box.

For countries such as Australia, New Zealand, South Africa, etc., please follow local wiring regulations!

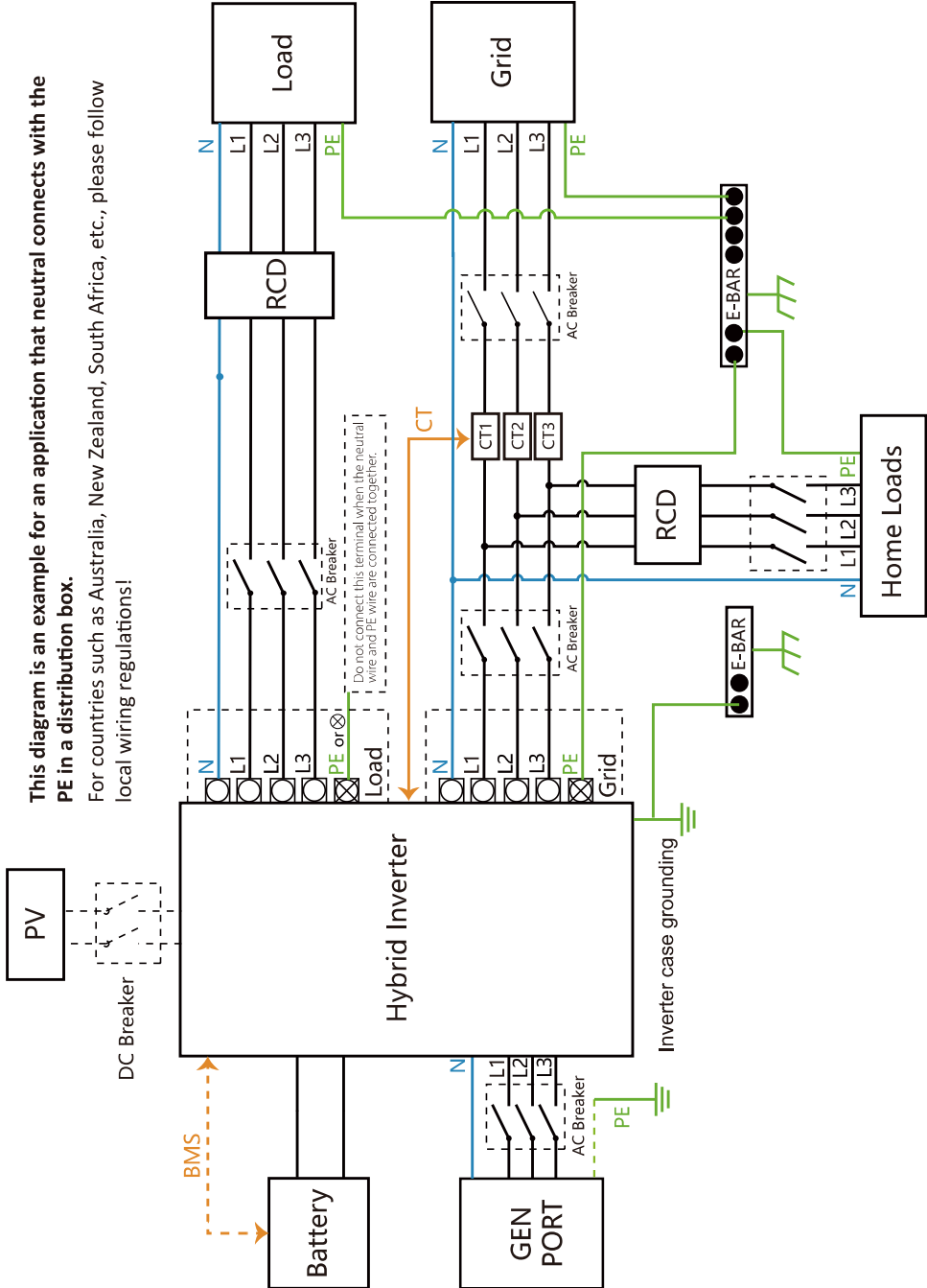

3.10 Wiring diagram

This diagram is an example for an application in which neutral is separated from the PE in the distribution box. For countries such as China, Germany, the Czech Republic, Italy, etc., please follow local wiring regulations!

Note: Backup function is optional in German market, please leave backup side empty if backup function is not available in the inverter.

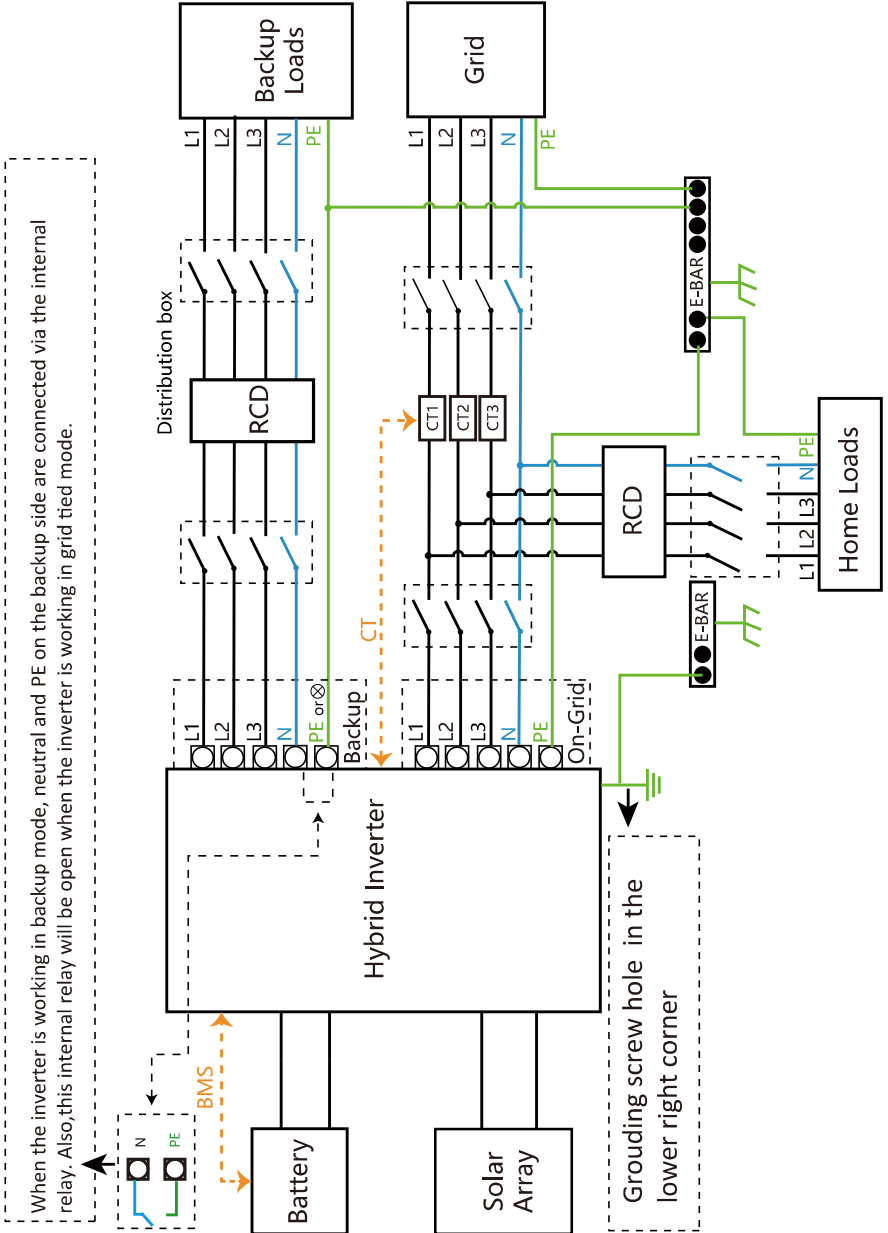

When the inverter is working in backup mode, neutral and PE on the backup side are connected via the internal relay. Also, this internal relay will be open when the inverter is working in grid tied mode.

— CAN
 — L wire
 — N wire
 — PE wire

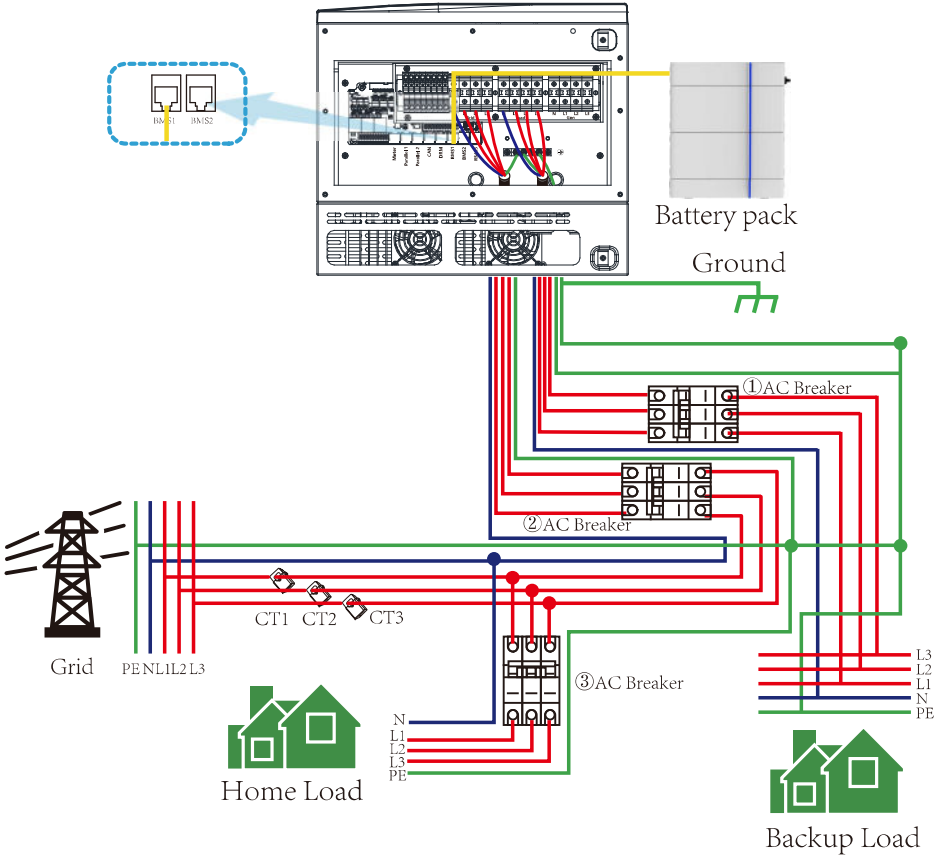

① AC Breaker for backup load
 GB-SL5K-EU: 100A AC breaker
 GB-SL6K-EU: 100A AC breaker
 GB-SL8K-EU: 100A AC breaker
 GB-SL10K-EU: 100A AC breaker
 GB-SL12K-EU: 100A AC breaker
 GB-SL15K-EU: 100A AC breaker
 GB-SL20K-EU: 100A AC breaker

② AC Breaker for grid
 GB-SL5K-EU: 100A AC breaker
 GB-SL6K-EU: 100A AC breaker
 GB-SL8K-EU: 100A AC breaker
 GB-SL10K-EU: 100A AC breaker
 GB-SL12K-EU: 100A AC breaker
 GB-SL15K-EU: 100A AC breaker
 GB-SL20K-EU: 100A AC breaker

③ AC Breaker for home load
 Depends on household loads

3.11 Typical application diagram of diesel generator

— CAN
 — L wire
 — N wire
 — PE wire

G-start (1,2): dry contact signal for startup the diesel generator.

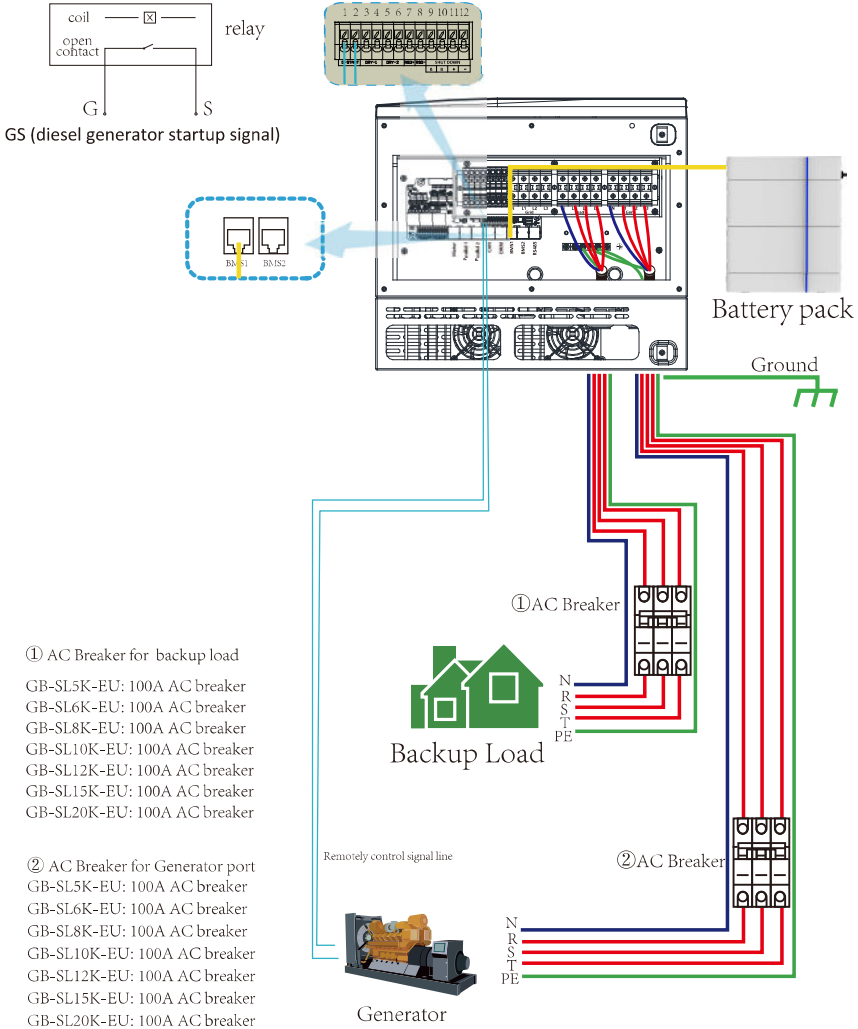

① AC Breaker for backup load

- GB-SL5K-EU: 100A AC breaker
- GB-SL6K-EU: 100A AC breaker
- GB-SL8K-EU: 100A AC breaker
- GB-SL10K-EU: 100A AC breaker
- GB-SL12K-EU: 100A AC breaker
- GB-SL15K-EU: 100A AC breaker
- GB-SL20K-EU: 100A AC breaker

② AC Breaker for Generator port

- GB-SL5K-EU: 100A AC breaker
- GB-SL6K-EU: 100A AC breaker
- GB-SL8K-EU: 100A AC breaker
- GB-SL10K-EU: 100A AC breaker
- GB-SL12K-EU: 100A AC breaker
- GB-SL15K-EU: 100A AC breaker
- GB-SL20K-EU: 100A AC breaker

3.12 Three phase parallel connection diagram

Note: The function of Multiple units work in parallel mode will be available in Q1 2023.

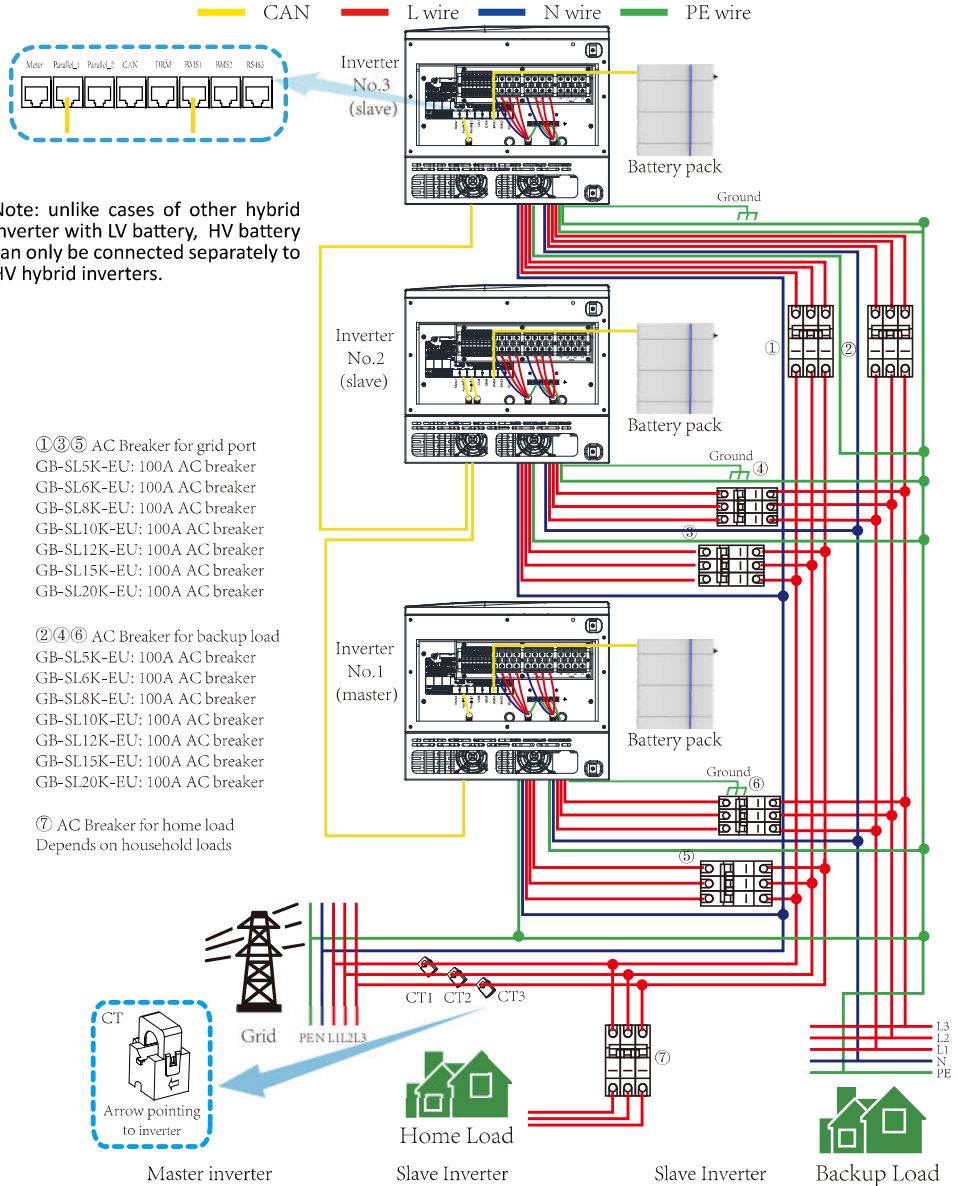

Note: unlike cases of other hybrid inverter with LV battery, HV battery can only be connected separately to HV hybrid inverters.

- ①③⑤ AC Breaker for grid port
- GB-SL5K-EU: 100A AC breaker
- GB-SL6K-EU: 100A AC breaker
- GB-SL8K-EU: 100A AC breaker
- GB-SL10K-EU: 100A AC breaker
- GB-SL12K-EU: 100A AC breaker
- GB-SL15K-EU: 100A AC breaker
- GB-SL20K-EU: 100A AC breaker

- ②④⑥ AC Breaker for backup load
- GB-SL5K-EU: 100A AC breaker
- GB-SL6K-EU: 100A AC breaker
- GB-SL8K-EU: 100A AC breaker
- GB-SL10K-EU: 100A AC breaker
- GB-SL12K-EU: 100A AC breaker
- GB-SL15K-EU: 100A AC breaker
- GB-SL20K-EU: 100A AC breaker

- ⑦ AC Breaker for home load
- Depends on household loads

Advanced Function

Parallel Modbus SN: 01

Master

Slave

EX_Meter For CT

Motor Subject: No Meter 03

Advanced Function

Parallel Modbus SN: 02

Master

Slave

EX_Meter For CT

Motor Subject: No Meter 03

Advanced Function

Parallel Modbus SN: 03

Master

Slave

EX_Meter For CT

Motor Subject: No Meter 03

4. OPERATION

4.1 Power ON/OFF

Once the unit has been properly installed and the batteries are connected well, simply press On/Off button(located on the left side of the case) to turn on the unit. When system without battery connected, but connect with either PV or grid, and ON/OFF button is switched off, LCD will still light up(Display will show OFF), In this condition, when switch on ON/OFF button and select NO battery,system can still working.

4.2 Operation and Display Panel

The operation and display panel, shown in below chart, is on the front panel of the inverter. It includes four indicators, four function keys and a LCD display, indicating the operating status and input/output power information.

<i>LED Indicator</i>		<i>Messages</i>
DC	Green led solid light	PV Connection normal
AC	Green led solid light	Grid Connection normal
Normal	Green led solid light	Inverter operating normal
Alarm	Red led solid light	Malfunction or warning

Chart 4-1 LED indicators

<i>Function Key</i>	<i>Description</i>
Esc	To exit setting mode
Up	To go to previous selection
Down	To go to next selection
Enter	To confirm the selection

Chart 4-2 Function Buttons

Light Meaning

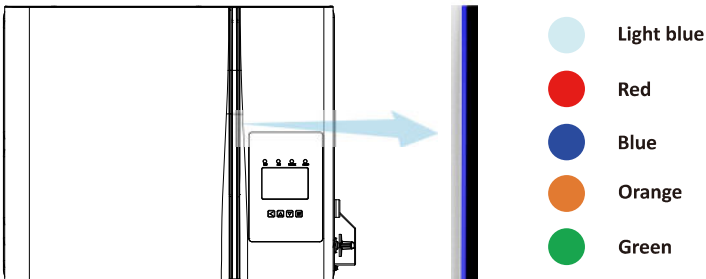

Light Meaning	Description
Self-check	Light-blue light, breathing at normal rate. If the duration exceeds 1 minute, restart the battery or contact maintenance personnel.
Fault	The red light is steady on when the system in faulty.
Normal	The blue light is steady on by default. If no PCS communication is available, the light switches to the breathing mode.
Alarm	Orange light, the light is always on when the insulation alarm is triggered.
Charging	Green light, breathing at normal rate.
Note:	After the single module undervoltage alarm or total undervoltage alarm is triggered, the light belt breath at a slower rate with the orange color. After the single module is less than 2.3V but greater than 0V, the RGB light function is turned off and will turn on again until the SOC is $\geq 15\%$.

Chart 4-2 Light Meaning

In addition to the LED lights, the battery fault information can be obtained through the screen and the upper computer. DEYE can also read these information through remote WLAN connection.

5. LCD Display Icons

5.1 Main Screen

The LCD is touchscreen, below screen shows the overall information of the inverter.

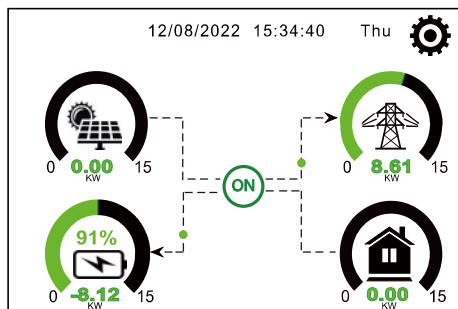

1. The icon in the center of the home screen indicates that the system is Normal operation. If it turns into "comm./F01~F64", it means the inverter has communication errors or other errors, the error message will display under this icon (F01-F64 errors, detail error info can be viewed in the System Alarms menu).

2. At the top of the screen is the time.

3. System Setup Icon, Press this set button, you can enter into the system setup screen which including Basic Setup, Battery Setup, Grid Setup, System Work Mode, Generator port use, Advanced function and Li-Batt info.

4. The main screen showing the info including Solar, Grid, Load and Battery. Its also displaying the energy flow direction by arrow. When the power is approximate to high level, the color on the panels will changing from green to red so system info showing vividly on the main screen.

- PV power and Load power always keep positive.
- Grid power negative means sell to grid, positive means get from grid.
- Battery power negative means charge, positive means discharge.

5.1.1 LCD operation flow chart

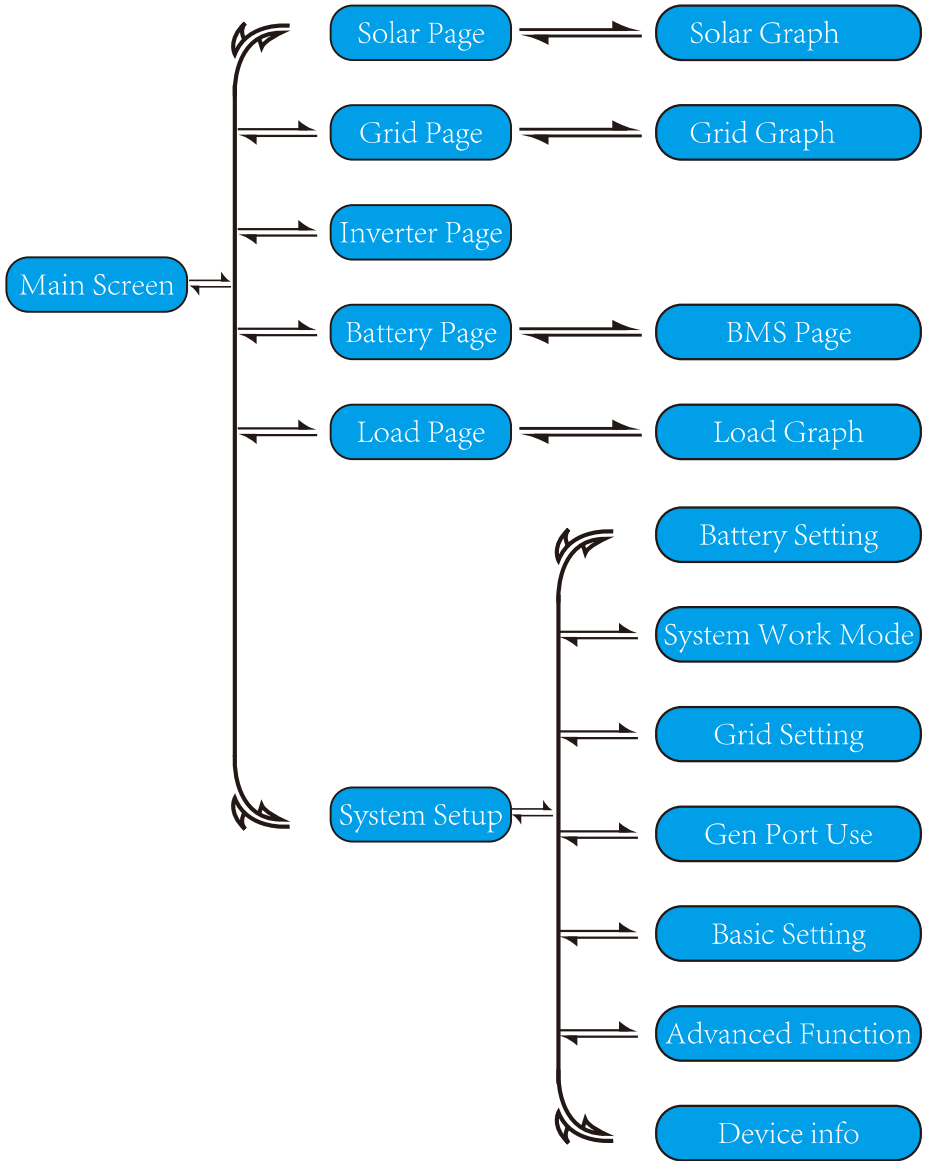

5.2 Solar Power Curve

Solar

PV1-V: 286V	PV1-I: 5.5A	PV1-P: 1559W
PV2-V: 286V	PV2-I: 5.5A	PV2-P: 1559W

Power: 1560W

Today=8.0 KWH
Total =12.00 KWH

Energy

This is Solar Panel detail page.

- ① Solar Panel Generation.
- ② Voltage, Current, Power for each MPPT.
- ③ Daily and total PV production.

Press the "Energy" button will enter into the power curve page.

1166w	1244w 50Hz	-81w 50Hz
221v 0w	222v 0.8w	222v 0.1A
229v 1166w	229v 5.0w	230v 0.1A
225v 0w	229v 0.9w	223v 0.1A
Load	HM: LD:	INV_P:
21w	-10W 28W	-30W
0w 0w	5W 1192W	-26W AC_T:
150V 150V	0W 24W	-25W 38.8C
-0.41A -0.41A	Grid	Inverter
27.0C 27.0C	0W 0W	0W 0.0A
Battery		PV

This is Inverter detail page.

- ① Inverter Generation.
- Voltage, Current, Power for each Phase.
- AC-T: mean Heat-sink temperature.

Load

Power: 55W

Today=0.5 KWH
Total =1.60 KWH

L1: 220V	P1: 19W
L2: 220V	P2: 18W
L3: 220V	P3: 18W

Energy

This is Back-up Load detail page.

- ① Back-up Power.
- ② Voltage, Power for each Phase.
- ③ Daily and total backup consumption .

Press the "Energy" button will enter into the power curve page.

Grid

Stand by
0W
0.0Hz

BUY
Today=2.2KWH
Total =11.60 KWH

SELL
Today=0.0KWH
Total =8.60 KWH

CT1: 0W	LD1: 0W
CT2: 0W	LD2: 0W
CT3: 0W	LD3: 0W

L1: 0V L2: 0V L3: 0V

Energy

This is Grid detail page.

- ① Status, Power, Frequency.
- ② L: Voltage for each Phase
CT: Power detected by the external current sensors
LD: Power detected using internal sensors on AC grid in/out breaker
- ③ BUY: Energy from Grid to Inverter,
SELL: Energy from Inverter to grid.

Press the "Energy" button will enter into the power curve page.

Batt

Battery 1
Stand by

U:170V
I:2.04A
Power: 101W
Temp:25.0C



This is Battery detail page.

if you use Lithium Battery, you can enter BMS page.

Li-BMS

Mean Voltage:170.0V Charging Voltage :180.0V
Total Current:37.00A Discharging Voltage :160.0V
Mean Temp :23.5C Charging current :30A
Total SOC :38% Discharging current :25A
Dump Energy:57Ah

Sum Data
Details Data

Li-BMS

	Volt	Curr	Temp	SOC	Energy	Charge		Fault
						Volt	Curr	
1	150.3V	18.70A	30.6C	52.0%	26.0Ah	0.0V	0.0A	0 0 0
2	150.0V	18.10A	31.0C	51.0%	25.5Ah	153.2V	25.0A	0 0 0
3	150.1V	16.90A	30.2C	12.0%	6.0Ah	153.2V	25.0A	0 0 0
4	0.00V	0.00A	0.0C	0.0%	0.0Ah	0.0V	0.0A	0 0 0
5	0.00V	0.00A	0.0C	0.0%	0.0Ah	0.0V	0.0A	0 0 0
6	0.00V	0.00A	0.0C	0.0%	0.0Ah	0.0V	0.0A	0 0 0
7	0.00V	0.00A	0.0C	0.0%	0.0Ah	0.0V	0.0A	0 0 0
8	0.00V	0.00A	0.0C	0.0%	0.0Ah	0.0V	0.0A	0 0 0
9	0.00V	0.00A	0.0C	0.0%	0.0Ah	0.0V	0.0A	0 0 0
10	0.00V	0.00A	0.0C	0.0%	0.0Ah	0.0V	0.0A	0 0 0
11	0.00V	0.00A	0.0C	0.0%	0.0Ah	0.0V	0.0A	0 0 0
12	0.00V	0.00A	0.0C	0.0%	0.0Ah	0.0V	0.0A	0 0 0
13	0.00V	0.00A	0.0C	0.0%	0.0Ah	0.0V	0.0A	0 0 0
14	0.00V	0.00A	0.0C	0.0%	0.0Ah	0.0V	0.0A	0 0 0
15	0.00V	0.00A	0.0C	0.0%	0.0Ah	0.0V	0.0A	0 0 0

Sum Data
Details Data

5.3 Curve Page-Solar & Load & Grid

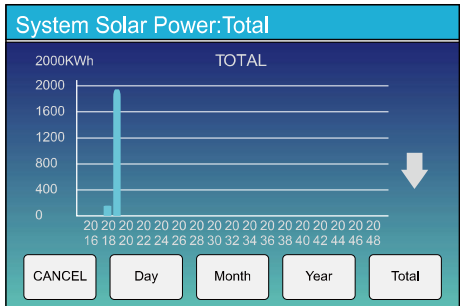
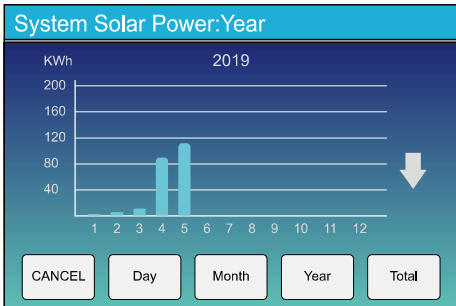
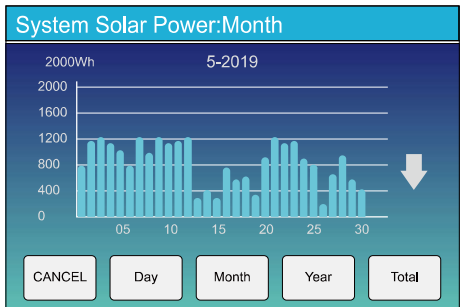
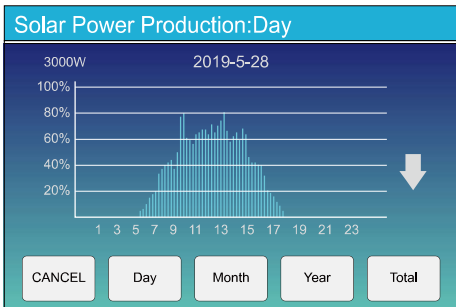

Solar power curve for daily, monthly, yearly and total can be roughly checked on the LCD, for more accuracy power generation, pls check on the monitoring system. Click the up and down arrow to check power curve of different period.

5.4 System Setup Menu

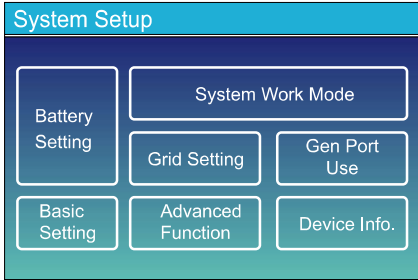

This is System Setup page.

5.5 Basic Setup Menu

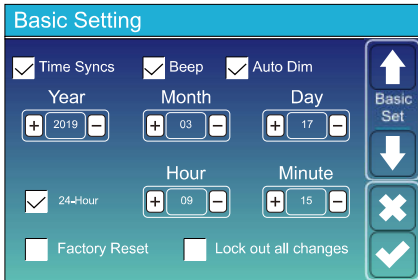

Factory Reset: Reset all parameters of the inverter.
Lock out all changes: Enable this menu for setting parameters that require locking and cannot be set up. Before performing a successful factory reset and locking the systems, to keep all changes you need to type in a password to enable the setting. The password for factory settings is 9999 and for lock out is 7777.

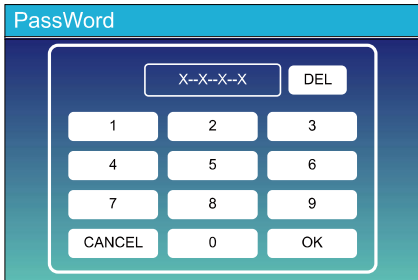

Factory Reset PassWork: 9999

Lock out all changes PassWork: 7777

5.6 Battery Setup Menu

Battery Setting

Batt Mode

Lithium Batt Capacity 0Ah

Use Batt V Max A Charge 0A

Use Batt % Max A Discharge 0A

No Batt

Activate Battery1 Parallel bat1&bat2

Activate Battery2

↑ Batt Mode

↓

✕

✓

Battery capacity: it shows your battery bank size to Deye hybrid inverter.

Use Batt V: Use Battery Voltage for all the settings (V).

Use Batt %: Use Battery SOC for all the settings (%).

Max. A charge/discharge: Max battery charge/discharge current(0-37A for 5/6/8/10/12/15/20KW model).

For AGM and Flooded, we recommend Ah battery size x 20%= Charge/Discharge amps.

. For Lithium, we recommend Ah battery size x 50% = Charge/Discharge amps.

. For Gel, follow manufacturer' s instructions.

No Batt: tick this item if no battery is connected to the system.

Activate Battery1/Activate Battery2: This feature will help recover a battery that is over discharged by slowly charging from the solar array or grid.

Battery Setting

Start 30% 30%

A 20A 37A

Gen Charge Grid Charge

Gen Signal Grid Signal

Gen Max Run Time 24.0 hours

Gen Down Time 0.0 hours

↑ Batt Set2

↓

✕

✓

This is Battery Setup page. ①

Start =30%: Percent SOC below 30% system will AutoStart a connected generator to charge the battery bank.

A = 20A: Charge rate of 20A from the attached generator in Amps.

Gen Charge: uses the gen input of the system to charge battery bank from an attached generator.

Gen Signal: Normally open relay that closes when the Gen Start signal state is active.

This is Grid Charge, you need select. ②

Start =30%: No use, Just for customization.

A = 37A: It indicates the Current that the Grid charges the Battery.

Grid Charge: It indicates that the grid charges the battery.

Grid Signal: Disable.

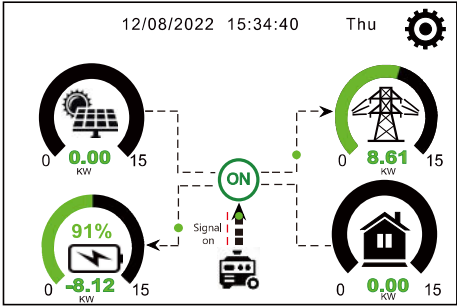

This page tells the PV and diesel generator power the load and battery.

Generator

Power: 6000W Today=10 KWH
 Total =10 KWH

V_L1: 230V	P_L1: 2KW
V_L2: 230V	P_L2: 2KW
V_L3: 230V	P_L3: 2KW

This page tells generator output voltage, frequency, power. And, how much energy is used from generator.

Battery Setting

Lithium Mode	00
Shutdown	10%
Low Batt	20%
Restart	40%

Batt Set3

Lithium Mode: This is BMS protocol. Please reference the document (Approved Battery).

Shutdown 10%: It indicates the inverter will shutdown if the SOC below this value.

Low Batt 20%: It indicates the inverter will alarm if the SOC below this value.

Restart 40%: Battery SOC at 40% AC output will resume.

Recommended battery settings

Battery Type	Absorption Stage	Float Stage	Torque value (every 30 days 3hr)
Lithium	Follow its BMS voltage parameters		

5.7 System Work Mode Setup Menu

System Work Mode

Selling First 12000 Max Solar Power

Zero Export To Load Solar Sell

Zero Export To CT Solar Sell

Max Sell Power 12000 Zero-export Power 20

Energy pattern BattFirst LoadFirst

Grid Peak Shaving 8000 Power

Work Mode
 ↑
 ↓
 ✕
 ✓

Work Mode

Selling First: This Mode allows hybrid inverter to sell back any excess power produced by the solar panels to the grid. If time of use is active, the battery energy also can be sold into grid.

The PV energy will be used to power the load and charge the battery and then excess energy will flow to grid.

Power source priority for the load is as follows:

1. Solar Panels.
2. Grid.
3. Batteries (until programable % discharge is reached).

Zero Export To Load: Hybrid inverter will only provide power to the backup load connected. The hybrid inverter will neither provide power to the home load nor sell power to grid. The built-in CT will detect power flowing back to the grid and will reduce the power of the inverter only to supply the local load and charge the battery.

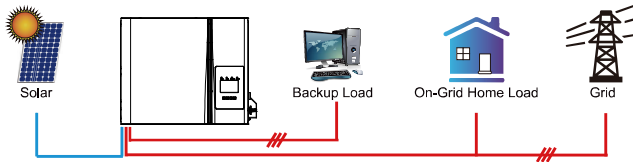

Zero Export To CT: Hybrid inverter will not only provide power to the backup load connected but also give power to the home load connected. If PV power and battery power is insufficient, it will take grid energy as supplement. The hybrid inverter will not sell power to grid. In this mode, a CT is needed. The installation method of the CT please refer to chapter 3.6 CT Connection. The external CT will detect power flowing back to the grid and will reduce the power of the inverter only to supply the local load, charge battery and home load.

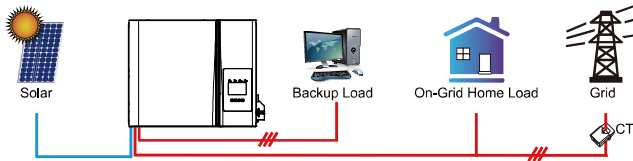

Solar Sell: “Solar sell” is for Zero export to load or Zero export to CT: when this item is active, the surplus energy can be sold back to grid. When it is active, PV Power source priority usage is as follows: load consumption and charge battery and feed into grid.

Max. sell power: Allowed the maximum output power to flow to grid.

Zero-export Power: for zero-export mode, it tells the grid output power. Recommend to set it as 20-100W to ensure the hybrid inverter won't feed power to grid.

Energy Pattern: PV Power source priority.

Batt First: PV power is firstly used to charge the battery and then used to power the load. If PV power is insufficient, grid will make supplement for battery and load simultaneously.

Load First: PV power is firstly used to power the load and then used to charge the battery. If PV power is insufficient, Grid will provide power to load.

Max Solar Power: allowed the maximum DC input power.

Grid Peak-shaving: when it is active, grid output power will be limited within the set value. If the load power exceeds the allowed value, it will take PV energy and battery as supplement. If still can't meet the load requirement, grid power will increase to meet the load needs.

System Work Mode

Grid Charge	Gen	Time	Power	Batt	
<input type="checkbox"/>	<input type="checkbox"/>	01:00	5:00	12000	160V
<input type="checkbox"/>	<input type="checkbox"/>	05:00	9:00	12000	160V
<input checked="" type="checkbox"/>	<input type="checkbox"/>	09:00	13:00	12000	160V
<input checked="" type="checkbox"/>	<input type="checkbox"/>	13:00	17:00	12000	160V
<input checked="" type="checkbox"/>	<input type="checkbox"/>	17:00	21:00	12000	160V
<input checked="" type="checkbox"/>	<input type="checkbox"/>	21:00	01:00	12000	160V

Time Of Use

Work Mode2

Battery Setting

Start

A

Gen Charge Grid Charge

Gen Signal Grid Signal

Gen Max Run Time

Gen Down Time

Batt Set2

System Work Mode

Grid Charge	Gen	Time	Power	Batt	
<input checked="" type="checkbox"/>	<input type="checkbox"/>	01:00	5:00	12000	80%
<input checked="" type="checkbox"/>	<input type="checkbox"/>	05:00	8:00	12000	40%
<input type="checkbox"/>	<input type="checkbox"/>	08:00	10:00	12000	40%
<input checked="" type="checkbox"/>	<input type="checkbox"/>	10:00	15:00	12000	100%
<input type="checkbox"/>	<input type="checkbox"/>	15:00	18:00	12000	40%
<input type="checkbox"/>	<input type="checkbox"/>	18:00	01:00	12000	35%

Time Of Use

Work Mode2

Time of use: it is used to program when to use grid or generator to charge the battery, and when to discharge the battery to power the load. Only tick "Time Of Use" then the follow items (Grid, charge, time, power etc.) will take effect.

Note: when in selling first mode and click time of use, the battery power can be sold into grid.

Gen charge: utilize diesel generator to charge the battery in a time period.

Time: real time, range of 01:00-24:00.

Note: when the grid is present, only the “time of use” is ticked, then the battery will discharge. Otherwise, the battery won't discharge even the battery SOC is full. But in the off-grid mode (when grid is not available, inverter will work in the off-grid mode automatically).

Power: Max. discharge power of battery allowed.

Batt(V or SOC %): battery SOC % or voltage at when the action is to happen.

For example

During 01:00-05:00,

if battery SOC is lower than 80%, it will use grid to charge the battery until battery SOC reaches 80%.

During 05:00-08:00,

if battery SOC is higher than 40%, hybrid inverter will discharge the battery until the SOC reaches 40%. At the same time, if battery SOC is lower than 40%, then grid will charge the battery SOC to 40%.

During 08:00-10:00,

if battery SOC is higher than 40%, hybrid inverter will discharge the battery until the SOC reaches 40%.

During 10:00-15:00,

when battery SOC is higher than 80%, hybrid inverter will discharge the battery until the SOC reaches 80%.

During 15:00-18:00,

when battery SOC is higher than 40%, hybrid inverter will discharge the battery until the SOC reaches 40%.

During 18:00-01:00,

when battery SOC is higher than 35%, hybrid inverter will discharge the battery until the SOC reaches 35%.

5.8 Grid Setup Menu

Grid Setting/Grid code selection

Grid Mode: 0/10

Grid Frequency: 50HZ 60HZ Phase Type: 0/120/240 0/240/120

Grid Level:

IT system-neutral is not grounded

Grid Set 1

Grid Set 2

Grid Set 3

Grid Mode: General Standard、UL1741 & IEEE1547、CPUC RULE21、SRD-UL-1741、CEI 0-21、Australia A、Australia B、Australia C、EN50549_CZ-PPDS(>16A)、NewZealand、VDE4105、OVE-Directive R25.

Please follow the local grid code and then choose the corresponding grid standard.

Grid level: there're several voltage levels for the inverter output voltage when it is in off-grid mode.

LN:230VAC LL:400VAC, LN:240VAC LL:420VAC, LN:120VAC LL:208VAC, LN:133VAC LL:230VAC.

IT system: For the IT grid system, the Line voltage

(between any two lines in a three-phase circuit) is 230Vac, and the diagram is as follow. If your grid system is IT system, please enable "IT system" and tick the "Grid level" as 133-3P as below picture shows.

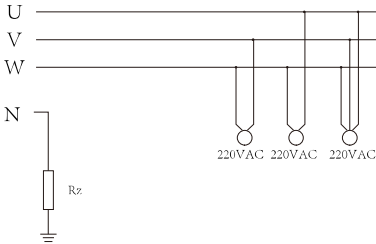

Rz: Large resistance ground resistor. Or the system doesn't have Neutral line

Grid Setting/Connect

Normal connect: Normal Ramp rate: 10s

Low frequency: 48.00Hz High frequency: 51.50Hz

Low voltage: 185.0V High voltage: 265.0V

Reconnect after trip: Reconnect Ramp rate: 36s

Low frequency: 48.20Hz High frequency: 51.30Hz

Low voltage: 187.0V High voltage: 263.0V

Reconnection Time: 60s PF: 1.000

Grid Set 2

Grid Set 3

Normal connect: The allowed grid voltage/frequency range when the inverter first time connect to the grid.
Normal Ramp rate: It is the startup power ramp.

Reconnect after trip: The allowed grid voltage /frequency range for the inverter connects the grid after the inverter trip from the grid.

Reconnect Ramp rate: It is the reconnection power ramp.

Reconnection time: The waiting time period for the inverter connects the grid again.

PF: Power factor which is used to adjust inverter reactive power.

Grid Setting/IP Protection

Over voltage $U_{>}$ (10 min, running mean): 260.0V

HV3: 265.0V HF3: 51.50Hz

HV2: 265.0V -- 0.10s HF2: 51.50Hz -- 0.10s

HV1: 265.0V -- 0.10s HF1: 51.50Hz -- 0.10s

LV1: 185.0V -- 0.10s LF1: 48.00Hz -- 0.10s

LV2: 185.0V -- 0.10s LF2: 48.00Hz -- 0.10s

LV3: 185.0V LF3: 48.00Hz

Grid Set 3

HV1: Level 1 overvoltage protection point;
① HV2: Level 2 overvoltage protection point; ② 0.10s—Trip time.
HV3: Level 3 overvoltage protection point.

LV1: Level 1 undervoltage protection point;
LV2: Level 2 undervoltage protection point;
LV3: Level 3 undervoltage protection point.

HF1: Level 1 over frequency protection point;
HF2: Level 2 over frequency protection point;
HF3: Level 3 over frequency protection point.

LF1: Level 1 under frequency protection point;
LF2: Level 2 under frequency protection point;
LF3: Level 3 under frequency protection point.

Grid Setting/F(W)

F(W)

Over frequency	Drop F	40%PE/Hz
Start freq F	Stop freq F	51.5Hz
Start delay F	Stop delay F	0.00s

Under frequency	Drop F	40%PE/Hz
Start freq F	Stop freq F	49.80Hz
Start delay F	Stop delay F	0.00s

Grid Set4

FW: this series inverter is able to adjust inverter output power according to grid frequency.

Drop F: percentage of nominal power per Hz. For example, "Start freq F > 50.2Hz, Stop freq F < 51.5, Drop F=40%PE/Hz" when the grid frequency reaches 50.2Hz, the inverter will decrease its active power at Drop F of 40%. And then when grid system frequency is less than 50.1Hz, the inverter will stop decreasing output power.

For the detailed setup values, please follow the local grid code.

Grid Setting/V(W) V(Q)

V(W) V(Q)

V1	108.0%	P1	100%
V2	110.0%	P2	80%
V3	112.0%	P3	60%
V4	114.0%	P4	40%

Lock-in/Pn	5%	Lock-out/Pn	20%
V1	94.0%	Q1	44%
V2	97.0%	Q2	0%
V3	105.0%	Q3	0%
V4	108.0%	Q4	-44%

Grid Set5

V(W): It is used to adjust the inverter active power according to the set grid voltage.

V(Q): It is used to adjust the inverter reactive power according to the set grid voltage.

This function is used to adjust inverter output power (active power and reactive power) when grid voltage changes.

Lock-in/Pn 5%: When the inverter active power is less than 5% rated power, the VQ mode will not take effect.

Lock-out/Pn 20%: If the inverter active power is increasing from 5% to 20% rated power, the VQ mode will take effect again.

For example: V2=110%, P2=80%. When the grid voltage reaches the 110% times of rated grid voltage, inverter output power will reduce its active output power to 80% rated power.

For example: V1=94%, Q1=44%. When the grid voltage reaches the 94% times of rated grid voltage, inverter output power will output 44% reactive output power.

For the detailed setup values, please follow the local grid code.

Grid Setting/P(Q) P(F)

P(Q) P(PF)

P1	0%	Q1	2%
P2	2%	Q2	0%
P3	0%	Q3	21%
P4	22%	Q4	25%

Lock-in/Pn	50%	Lock-out/Pn	50%
P1	0%	PF1	-0.000
P2	0%	PF2	-0.000
P3	0%	PF3	0.000
P4	62%	PF4	0.264

Grid Set6

P(Q): It is used to adjust the inverter reactive power according to the set active power.

P(PF): It is used to adjust the inverter PF according to the set active power.

For the detailed setup values, please follow the local grid code.

Lock-in/Pn 50%: When the inverter output active power is less than 50% rated power, it won't enter the P(PF) mode.

Lock-out/Pn 50%: Lock-out/Pn 50%: When the inverter output active power is higher than 50% rated power, it will enter the P(PF) mode.

Note : only when the grid voltage is equal to or higher than 1.05times of rated grid voltage, then the P(PF) mode will take effect.

Grid Setting/LVRT

L/HVRT

HV3	0%	HV3_T	30.24s
HV2	0%	HV2_T	0.04s
HV1	0%	HV1_T	22.11s
LV1	0%	LV1_T	22.02s
LV2	0%	LV2_T	0.04s

Grid Set7

Reserved: This function is reserved.It is not recommended.

5.9 Generator Port Use Setup Menu

GEN PORT USE

Mode

Generator Input GEN connect to Grid input

Rated Power:

SmartLoad Output On Grid always on

AC Couple Frz High:

Micro Inv Input OFF: ON:

MI export to Grid cutoff

↑

PORT Set1

↓

✕

✓

Generator input rated power: allowed Max. power from diesel generator.

GEN connect to grid input: connect the diesel generator to the grid input port.

Smart Load Output: This mode utilizes the Gen input connection as an output which only receives power when the battery SOC is above a user programmable threshold.

e.g. ON: 100%, OFF: 95%: When the battery bank SOC reaches 100%, Smart Load Port will switch on automatically and power the load connected. When the battery bank SOC < 95% , the Smart Load Port will switch off automatically.

Smart Load OFF Batt

- Battery SOC at which the Smart load will switch off.

Smart Load ON Batt

- Battery SOC at which the Smart load will switch on. simultaneously and then the Smart load will switch on.

On Grid always on: When click "on Grid always on" the smart load will switch on when the grid is present.

Micro Inv Input: To use the Generator input port as a micro-inverter on grid inverter input (AC coupled), this feature will also work with "Grid-Tied" inverters.

- * **Micro Inv Input OFF:** when the battery SOC exceeds setting value, Microinverter or grid-tied inverter will shut down.
- * **Micro Inv Input ON:** when the battery SOC is lower than setting value, Microinverter or grid-tied inverter will start to work.

AC Couple Frz High: If choosing "Micro Inv input", as the battery SOC reaches gradually setting value (OFF), during the process, the microinverter output power will decrease linear. When the battery SOC equals to the setting value (OFF), the system frequency will become the setting value (AC couple Frz high) and the Microinverter will stop working. MI export to grid cutoff: Stop exporting power produced by the microinverter to the grid.

* **Note:** Micro Inv Input OFF and On is valid for some certain FW version only.

5.10 Advanced Function Setup Menu

Advanced Function

Solar Arc Fault: ON Backup Delay:

Clear Arc_Fault

System selfcheck Gen peak-shaving

DRM 2000: 1 CT Ratio

Signal Island Mode BMS_Err_Stop

Asymmetric phase feeding CEI Report

↑

Func Set1

↓

✕

✓

Solar Arc Fault ON: This is only for US.

System selfcheck: Disable. this is only for factory.

Gen Peak-shaving: Enable When the power of the generator exceeds the rated value of it, the inverter will provide the redundant part to ensure that the generator will not overload.

DRM: For AS4777 standard

Backup Delay: Reserved

BMS_Err_Stop: When it is active, if the battery BMS failed to communicate with inverter, the inverter will stop working and report fault.

Signal island mode: If "Signal island mode" is checked and When inverter is in off-grid mode, the relay on the Neutral line (load port N line) will switch ON then the N line (load port N line) will bind to inverter ground.

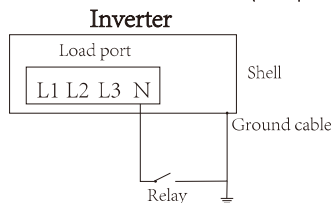

Asymmetric phase feeding: If it was checked, the excess PV energy that feeds into the grid will be balanced on the three phase.

Advanced Function

Parallel Modbus SN
 Master 00
 Slave

EX_Meter For CT

Meter Select

No Meter 0/3

CHNT
Eastron

↑ Par. Set3
↓
✕
✓

Ex_Meter For CT: when using zero-export to CT mode, the hybrid inverter can select EX_Meter For CT function and use the different meters.e.g.CHNT and Eastron.

5.11 Device Info Setup Menu

Device Info.

Inverter ID: 2102199870 Flash

HMI: Ver 1001-8010 MAIN:Ver2002-1046-1707

Alarms Code	Occurred
F13 Grid_Mode_changed	2021-06-11 13:17
F23 Tz_GFCI_OC_Fault	2021-06-11 08:23
F13 Grid_Mode_changed	2021-06-11 08:21
F56 DC_VoltLow_Fault	2021-06-10 13:05

Device Info

↑
↓
✕
✓

This page show Inverter ID, Inverter version and alarm codes.

HMI: LCD version

MAIN: Control board FW version

6. Mode

Mode I:Basic

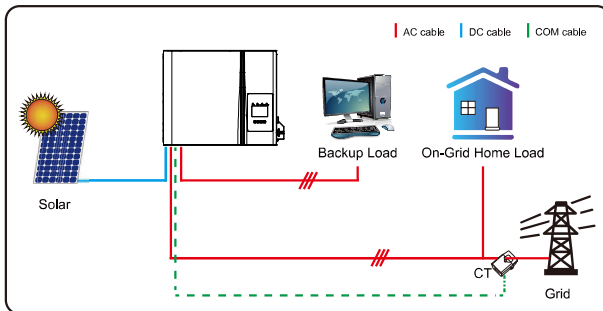

Mode II: With Generator

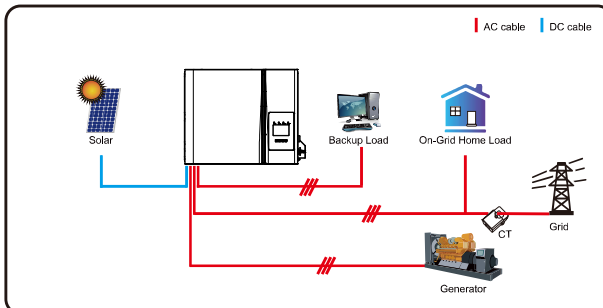

Mode III: With Smart-Load

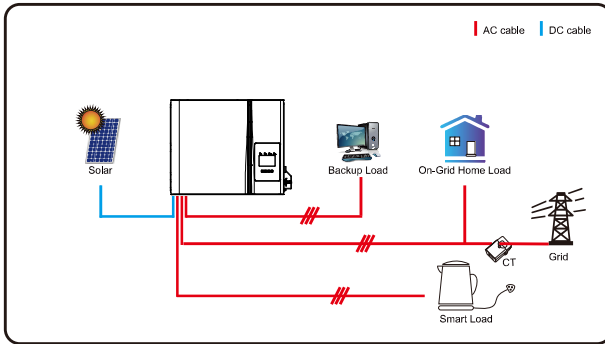

Mode IV: AC Couple

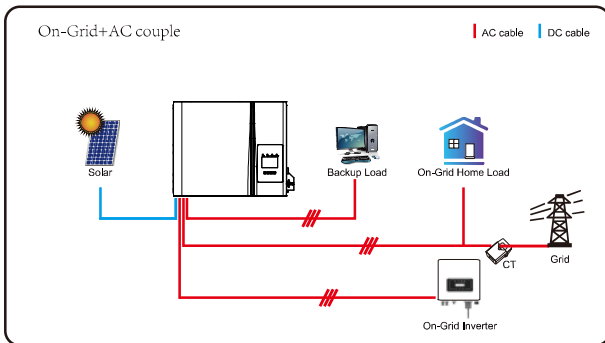

The 1st priority power of the system is always the PV power, then 2nd and 3rd priority power will be the battery bank or grid according to the settings. The last power backup will be the Generator if it is available.

7. Limitation of Liability

In addition to the product warranty described above, the state and local laws and regulations provide financial compensation for the product's power connection (including violation of implied terms and warranties). The company hereby declares that the terms and conditions of the product and the policy cannot and can only legally exclude all liability within a limited scope.

Error code	Description	Solutions
F01	DC_Inversed_Failure	<ol style="list-style-type: none"> 1, Check the PV input polarity 2, Seek help from us, if can not go back to normal state.
F07	DC_START_Failure	<ol style="list-style-type: none"> 1, The BUS voltage can't be built from PV or battery. 2, Restart the inverter, If the fault still exists, please contact us for help
F13	Working_Mode_change	<ol style="list-style-type: none"> 1. When the grid type and frequency changed it will report F13; 2. When the battery mode was changed to "No battery" mode, it will report F13; 3. For some old FW version, it will report F13 when the system work mode changed; 4. Generally, it will disappear automatically when shows F13; 5. If it remains same, turn on DC and AC switch for one minute, then turn on the DC and AC switch.; 6. Seek help from us, if can not go back to normal state.
F15	AC_OverCurr_SW_Failure	<p>AC side over current fault</p> <ol style="list-style-type: none"> 1. Please check whether the backup load power and common load power are within the range; 2. Restart and check whether it is normal; 3. Seek help from us, if can not go back to normal state.
F16	GFCL_Failure	<p>Leakage current fault</p> <ol style="list-style-type: none"> 1, Check the PV side cable ground connection 2, Restart the system 2-3 times 3, if the fault still existing, please contact us for help.
F18	Tz_Ac_OverCurr_Fault	<p>AC side over current fault</p> <ol style="list-style-type: none"> 1. Please check whether the backup load power and commonload power are within the range; 2. Restart and check whether it is normal; 3. Seek help from us, if cannot go back to normal state.
F20	Tz_Dc_OverCurr_Fault	<p>DC side over current fault</p> <ol style="list-style-type: none"> 1. Check PV module connection and battery connection; 2. When in the off-grid mode, the inverter startup with big power load, it may report F20. Please reduce the load power connected; 3. If it remains same, turn on DC and AC switch for one minute, then turn on the DC and AC switch.; 4. Seek help from us, if can not go back to normal state.

Error code	Description	Solutions
F21	Tz_HV_Overcurr_fault	BUS over current. 1. Check the PV input current and battery current setting 2. Restart the system 2~3 times. 3. If the fault still exists, please contact us for help.
F22	Tz_EmergStop_Fault	Remotely shutdown 1, it tells the inverter is remotely controlled.
F23	Tz_GFCI_OC_Fault	Leakage current fault 1. Check PV side cable ground connection. 2. Restart the system 2~3 times. 3. If the fault still exists, please contact us for help.
F24	DC_Insulation_Fault	PV isolation resistance is too low 1. Check the connection of PV panels and inverter is firmly and correctly; 2. Check whether the PE cable of inverter is connected to ground; 3. Seek help from us, if can not go back to normal state.
F26	BusUnbalance_Fault	1. Please wait for a while and check whether it is normal; 2. When the load power of 3 phases is big different, it will report the F26. 3. When there's DC leakage current, it will report F26 4. Restart the system 2~3 times. 5. Seek help from us, if can not go back to normal state.
F29	Parallel_Comm_Fault	1. When in parallel mode, check the parallel communication cable connection and hybrid inverter communication address setting; 2. During the parallel system startup period, inverters will report F29. But when all inverters are in ON status, it will disappear automatically; 3. If the fault still exists, please contact us for help.
F34	AC_Overload_Fault	1, Check the backup load connection, make sure it is in allowed power range 2, If the fault still exists, please contact us for help
F41	Parallel_system_Stop	1, Check the hybrid inverter work status. If there's 1pcs hybrid inverter shutdown, all hybrid inverters will report F41 fault. 2, If the fault still exists, please contact us for help
F42	Parallel_Version_Fault	Grid voltage fault 1. Check whether the AC voltage is within grid standard protection limits.; 2. Check whether grid AC cables are firmly and correctly connected; 3. Seek help from us, if can not go back to normal state.

Error code	Description	Solutions
F47	AC_OverFreq_Fault	Grid frequency out of range 1. Check the frequency is in the range of specification or not; 2. Check whether AC cables are firmly and correctly connected; 3. Seek help from us, if can not go back to normal state.
F48	AC_UnderFreq_Fault	Grid frequency out of range 1. Check the frequency is in the range of specification or not; 2. Check whether AC cables are firmly and correctly connected; 3. Seek help from us, if can not go back to normal state.
F52	DC_VoltHigh_Fault	BUS voltage is too high 1. Check whether battery voltage is too high; 2. check the PV input voltage, make sure it is within the allowed range; 3. Seek help from us, if can not go back to normal state.
F53	DC_VoltLow_Fault	BUS voltage is too low 1. Check whether battery voltage is too low; 2. If the battery voltage is too low, using PV or grid to charge the battery; 3. Seek help from us, if can not go back to normal state.
F54	BAT2_VoltHigh_Fault	1. Check the battery 2 terminal voltage is high; 2. Restart the inverter 2 times and restore the factory settings; 3. Seek help from us, if can not go back to normal state.
F55	BAT1_VoltHigh_Fault	1. Check the battery 1 terminal voltage is high; 2. Restart the inverter 2 times and restore the factory settings; 3. Seek help from us, if can not go back to normal state.
F56	BAT1_VoltLow_Fault	1. Check the battery 1 terminal voltage is low; 2. Restart the inverter 2 times and restore the factory settings; 3. Seek help from us, if can not go back to normal state.
F57	BAT2_VoltLow_Fault	1. Check the battery 2 terminal voltage is low; 2. Restart the inverter 2 times and restore the factory settings; 3. Seek help from us, if can not go back to normal state.
F58	Battery_comm_Lose	1, It tells the communication between hybrid inverter and battery BMS disconnected when “BMS_Err-Stop” is active; 2, If don't want to see this happen, you can disable “BMS_Err-Stop” item on the LCD; 3, If the fault still exists, please contact us for help
F62	DRMs0_stop	1, the DRM function is for Australia market only; 2, Check the DRM function is active or not; 3, Seek help from us, if can not go back to normal state after restart the system.
F63	ARC_Fault	1. ARC fault detection is only for US market; 2. Check PV module cable connection and clear the fault; 3. Seek help from us, if can not go back to normal state
F64	Heatsink_HighTemp_Fault	Heat sink temperature is too high 1. Check whether the working environment temperature is too high; 2. Turn off the inverter for 10mins and restart; 3. Seek help from us, if can not go back to normal state.

Chart 7-1 Fault information

Under the guidance of our company, customers return our products so that our company can provide service of maintenance or replacement of products of the same value. Customers need to pay the necessary freight and other related costs. Any replacement or repair of the product will cover the remaining warranty period of the product. If any part of the product or product is replaced by the company itself during the warranty period, all rights and interests of the replacement product or component belong to the company.

Factory warranty does not include damage due to the following reasons:

- Damage during transportation of equipment ;
- Damage caused by incorrect installation or commissioning ;
- Damage caused by failure to comply with operation instructions, installation instructions or maintenance instructions ;
- Damage caused by attempts to modify, alter or repair products ;
- Damage caused by incorrect use or operation ;
- Damage caused by insufficient ventilation of equipment ;
- Damage caused by failure to comply with applicable safety standards or regulations ;
- Damage caused by natural disasters or force majeure (e.g. floods, lightning, overvoltage, storms, fires, etc.)

In addition, normal wear or any other failure will not affect the basic operation of the product. Any external scratches, stains or natural mechanical wear does not represent a defect in the product.

8. Datasheet

<i>Model</i>	<i>GB-SL5K-EU</i>	<i>GB-SL6K-EU</i>	<i>GB-SL8K-EU</i>	<i>GB-SL10K-EU</i>	<i>GB-SL12K-EU</i>	<i>GB-SL15K-EU</i>	<i>GB-SL20K-EU</i>
Battery Input Data							
Battery Type	Li-Ion						
Battery Voltage Range(V)	160~700						
Max. Charging Current(A)	37						
Max. Discharging Current(A)	37						
Number of battery input	1						
Charging Strategy for Li-Ion Battery	Self-adaption to BMS						
PV String Input Data							
Max. DC Input Power(W)	6500	7800	10400	13000	15600	19500	26000
Max. DC Input Voltage (V)	1000						
MPPT Range(V)	150-850						
Start-up Voltage(V)	180						
Full Load DC Voltage Range (V)	195-850	195-850	260-850	325-850	340-850	420-850	500-850
Rated DC Input Voltage (V)	600						
PV Input Current(A)	20+20	20+20	20+20	20+20	26+20	26+20	26+26
Max.PV Isc(A)	30+30	30+30	30+30	30+30	39+30	39+30	39+39
No. of MPPT Trackers	2						
No. of Strings Per MPPT Tracker	1+1	1+1	1+1	1+1	2+1	2+1	2+2
AC Output Data							
Rated AC Output and UPS Power(W)	5000	6000	8000	10000	12000	15000	20000
Max. AC Output Power(W)	5500	6600	8800	11000	13200	16500	22000
Peak Power(off grid)	1.5 time of rated power, 10 S						
AC Output Rated Current(A)	7.6/7.3	9.1/8.7	12.2/11.6	15.2/14.5	18.2/17.4	22.8/21.8	30.4/29.0
Max. AC Current(A)	8.4/8.0	10/9.6	13.4/12.8	16.7/16	20/19.2	25/24	33.4/31.9
Max. Three-phase Unbalanced Output Current (A)	13	13	18	22	25	30	35
Max. Continuous AC Passthrough(A)	40				80		
Power Factor	0.8 leading to 0.8 lagging						
Output Frequency and Voltage	50/60Hz; 3L/N/PE 220/380, 230/400Vac						
Grid Type	Three Phase						
Total Harmonic Distortion (THD)	<3% (of nominal power)						
DC current injection	<0.5% In						
Efficiency							
Max. Efficiency	97.60%						
Euro Efficiency	97.00%						
MPPT Efficiency	>99%						
Protection							
PV Input Lightning Protection	Integrated						
Anti-islanding Protection	Integrated						
PV String Input Reverse Polarity Protection	Integrated						
Insulation Resistor Detection	Integrated						
Residual Current Monitoring Unit	Integrated						
Output Over Current Protection	Integrated						
Output Shorted Protection	Integrated						
Output Over Voltage Protection	DC Type II / AC Type II						
Battery Over Current Protection	Fuses						

Certifications and Standards	
Grid Regulation	VDE4105,IEC61727/62116,VDE0126,AS4777.2,CEI 0 21,EN50549-1, G98,G99,C10-11,UNE217002,NBR16149/NBR16150
EMC/Safety Regulation	IEC62109-1/-2, NBT32004-2018, EN61000-6-1,EN61000-6-2, EN61000-6-3, EN61000-6-4
General Data	
Operating Temperature Range(C)	-40~60 C , >45 C Derating
Cooling	Smart cooling
Noise(dB)	≤55 dB
Communication with BMS	RS485; CAN
Weight(kg)	30.5
Size(mm)	408W×638H×237D
Protection Degree	IP65
Installation Style	Wall-mounted
Warranty	5 years

9. Appendix I

Definition of RJ45 Port Pin for BMS1

No.	RS485 Pin
1	485_B
2	485_A
3	GND_485
4	CAN-H1
5	CAN-L1
6	GND_485
7	485_A
8	485_B

BMS1 Port

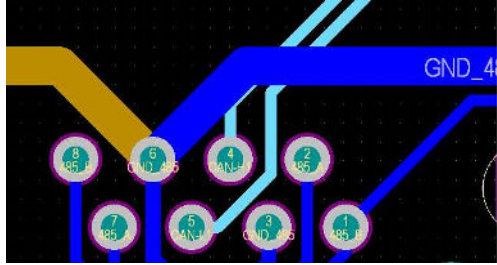
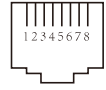
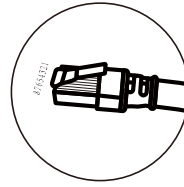

Definition of RJ45 Port Pin for BMS2

No.	RS485 Pin
1	485_B
2	485_A
3	GND_485
4	CAN-H2
5	CAN-L2
6	GND_485
7	485_A
8	485_B

BMS2 Port

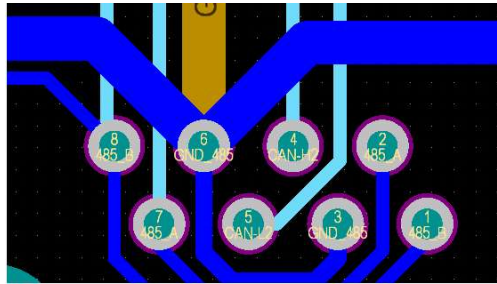

Definition of RJ45 Port Pin for Meter

No.	Meter-485 Pin
1	METER-485_B
2	METER-485_A
3	GND_COM
4	METER-485_B
5	METER-485_A
6	GND_COM
7	--
8	--

Meter Port

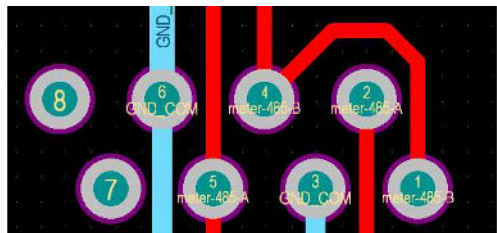
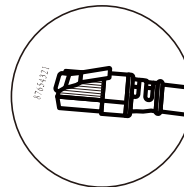

Definition of RJ45 Port Pin for RS485

No.	RS485 Pin
1	Modbus-485_B
2	Modbus-485_A
3	GND_485
4	--
5	--
6	GND_485
7	Modbus-485_A
8	Modbus-485_B

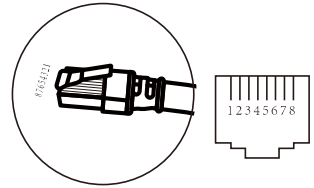

RS485 Port

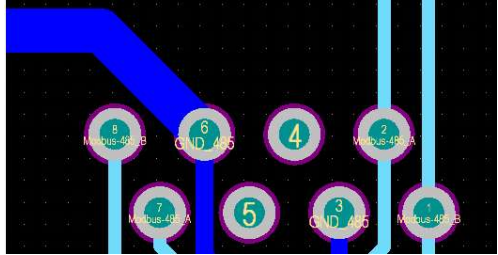

RS232

No.	WIFI/RS232
1	
2	TX
3	RX
4	
5	D-GND
6	
7	
8	
9	12Vdc

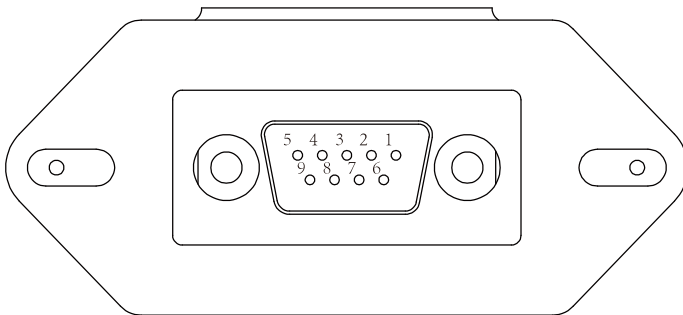

WIFI/RS232

This RS232 port is used to connect the wifi datalogger

10. Appendix II

1. Split Core Current Transformer (CT) dimension: (mm)
2. Secondary output cable length is 4m.

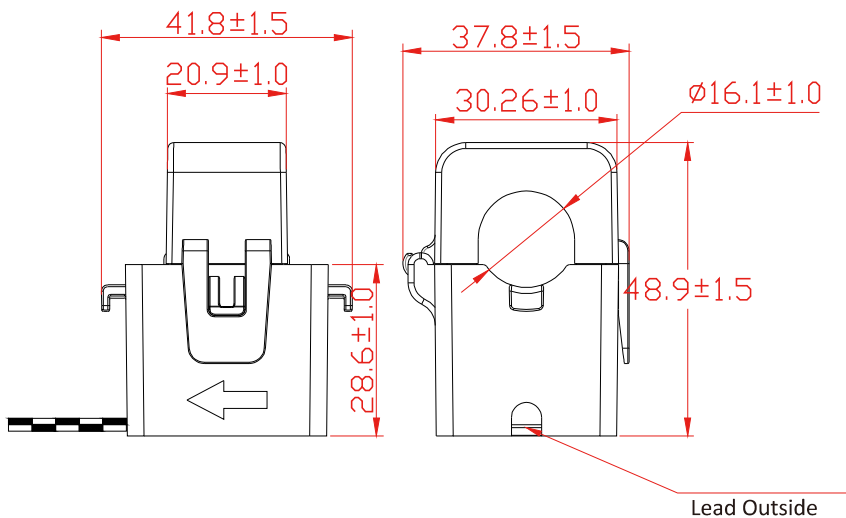

NINGBO DEYE INVERTER TECHNOLOGY CO., LTD.

Add: No.26-30, South Yongjiang Road, Beilun, 315806, Ningbo, China

Tel: +86 (0) 574 8622 8957

Fax: +86 (0) 574 8622 8852

E-mail: service@deye.com.cn

Web: www.deyeinverter.com