

LUNA2000-(97KWH-1H1, 129KWH-2H1, 161KWH-2H1, 200KWH-2H1) Smart String ESS

Quick Guide

Issue: 05
Part Number: 31500HTW
Date: 2023-09-12



NOTICE

- **Before installing the equipment, read the user manual carefully to get familiar with product information and safety precautions. The product warranty does not cover equipment damage caused by failure to follow the storage, transportation, installation, and usage guidelines specified in this document and the user manual. Scan the QR code near the nameplate or the air conditioner in the cabinet to view the user manual and safety precautions.**
- The information in this document is subject to change without notice. Every effort has been made in the preparation of this document to ensure accuracy of the contents, but all statements, information, and recommendations in this document do not constitute a warranty of any kind, express or implied.
- Only qualified professionals or trained personnel are allowed to perform operations on the equipment. Operation personnel shall understand the system, its working principles, and relevant national/regional standards.
- Do not transport the Smart String Energy Storage System (also referred to as ESS) with battery packs installed.
- Use insulated tools and wear proper personal protective equipment (PPE) when installing the equipment.
- During the installation or operation, close cabinet doors if you leave even for a short time.
- If the paint is damaged due to collision during transportation or installation, use the RAL9003 outdoor paint to repair the damaged area.
- For details about the binding positions of the delivered mounting brackets and screws, see the packing list.

1 Appearance

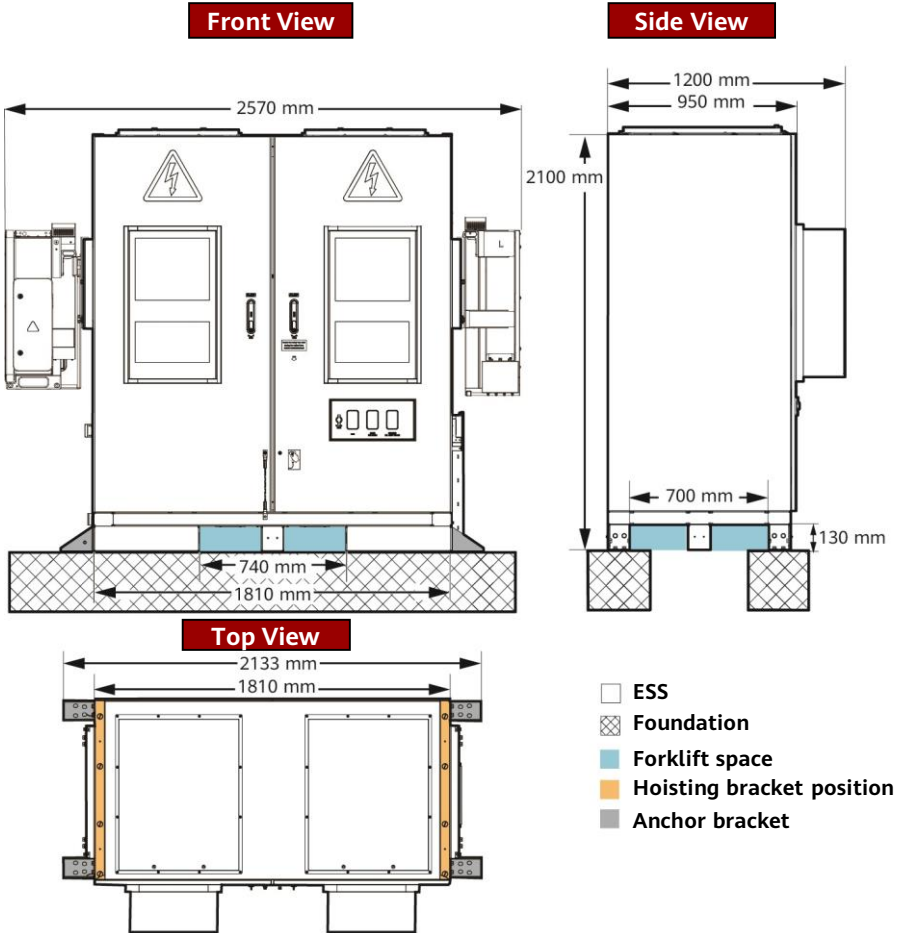

IB03W00026

NOTE

The site foundation must be designed by professional technical personnel such as those from a design institute. The technical personnel can refer to the foundation drawings of the Company. Contact the product manager of the Company to obtain the drawings.

2 Clearance Requirements

NOTICE

The following figure shows the minimum clearance requirements for installation and O&M. The equipment clearances must also meet the site selection requirements. For details, see the user manual.

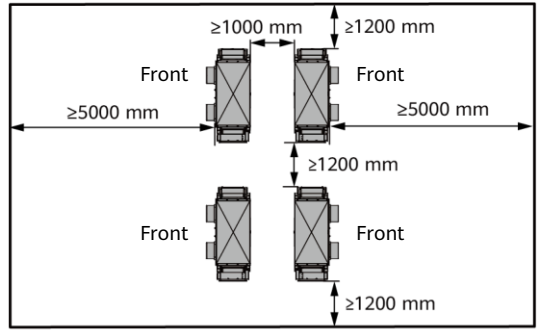
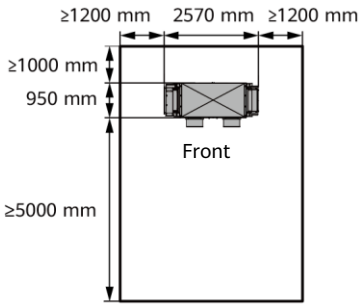

IB03W00050

3 Installing the ESS

NOTE

This document uses the 200 kWh model as an example. The actual structure of a model may vary.

1. Remove the baffle plate from the bottom of the ESS.

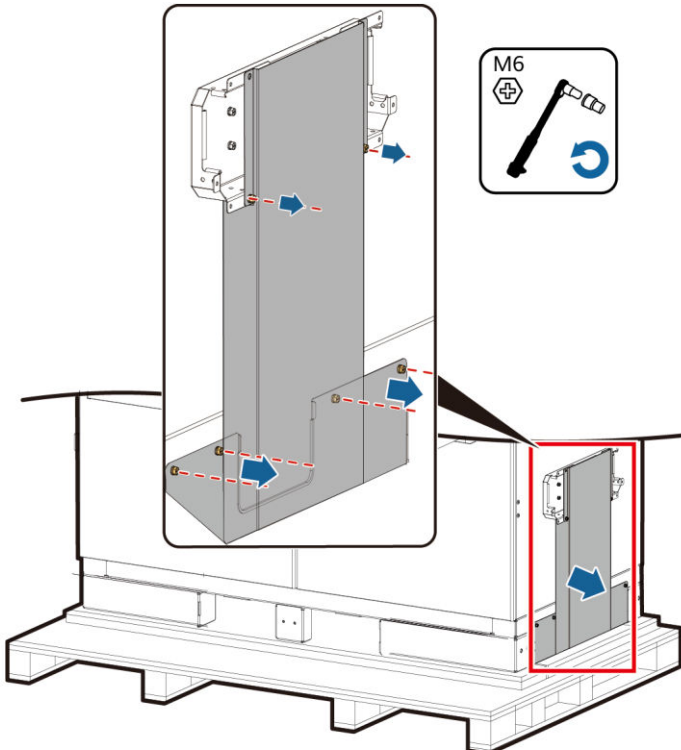

IB03H00009

2. Remove the pallets.

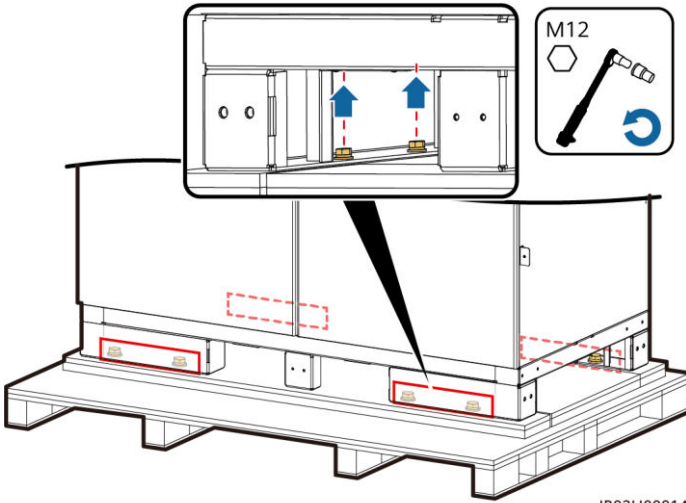

3. Install the baffle plate to the bottom of the ESS.

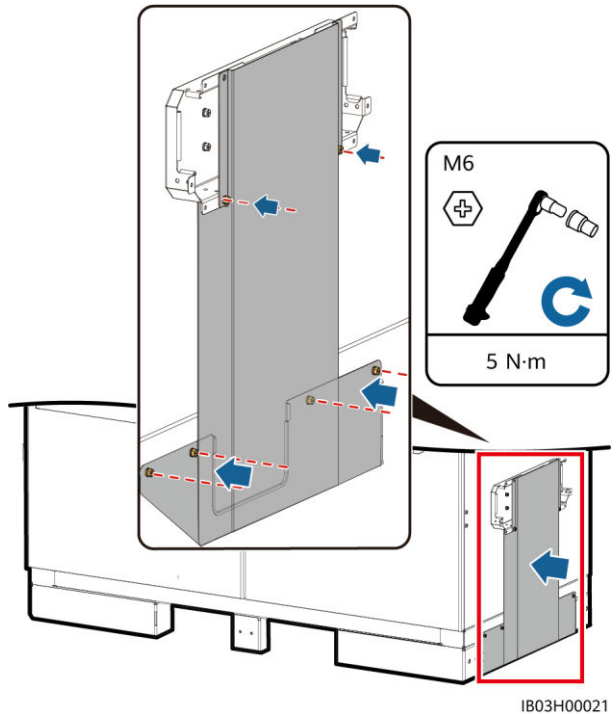

4. Open the cabinet doors.

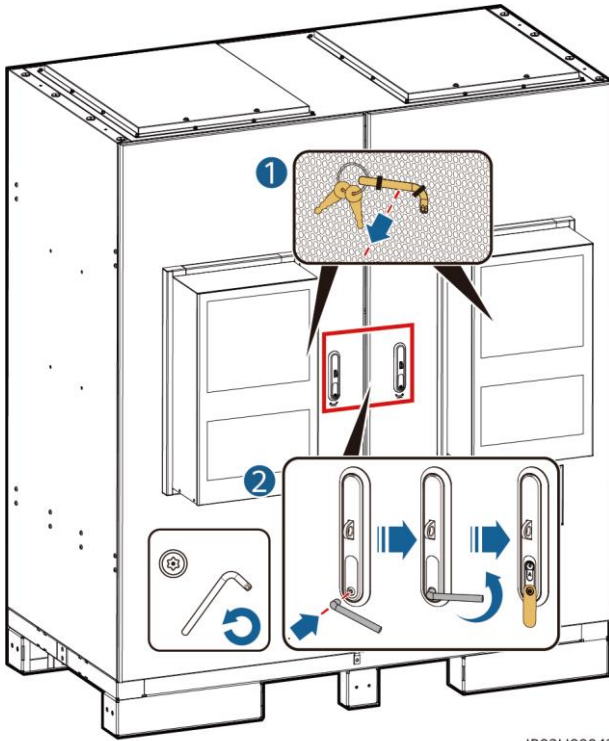

IB03H00042

5. Take out the delivered documents, such as the packing list.

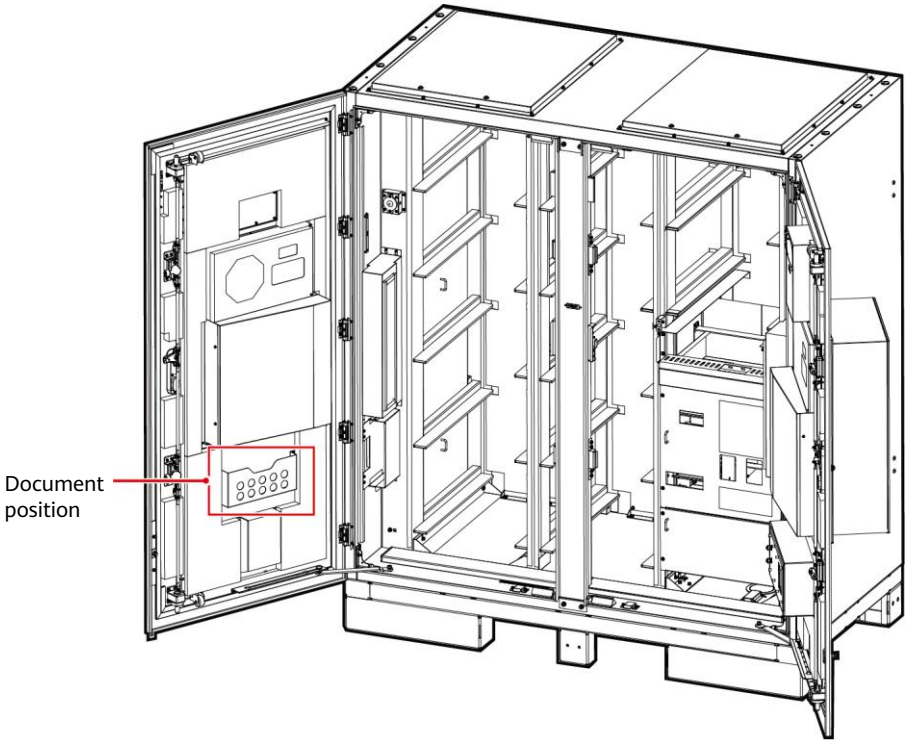

IB03W00027

6. Take out the mounting brackets delivered with the product.

NOTE

After opening the doors, check the number of deliverables based on the packing list. If any deliverable is missing, contact your dealer immediately.

Hoisting bracket and screw		Anchor bracket, anchor bracket screw, and expansion bolt			Leveling spacer

7. After closing the cabinet doors, move the ESS to the specified position.

Using a Crane

NOTE

Crane hoisting capacity ≥ 2 t,
working radius ≥ 2 m

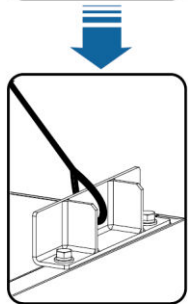
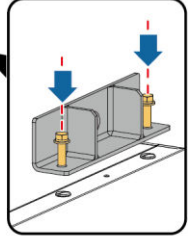
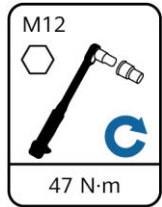
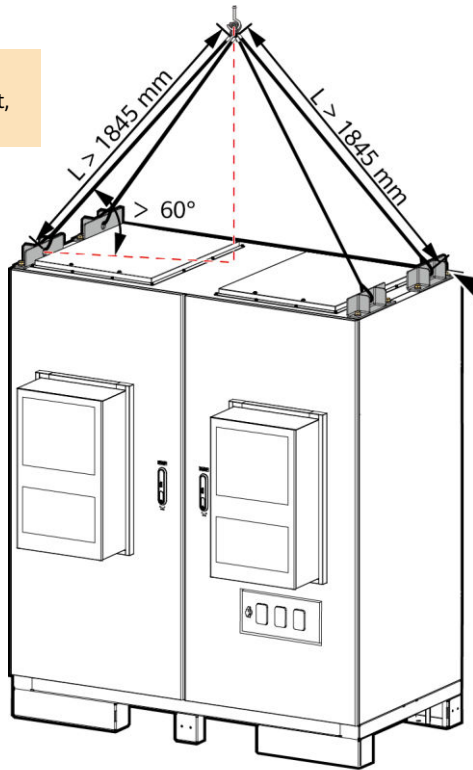

IB03H00038

Using a Forklift

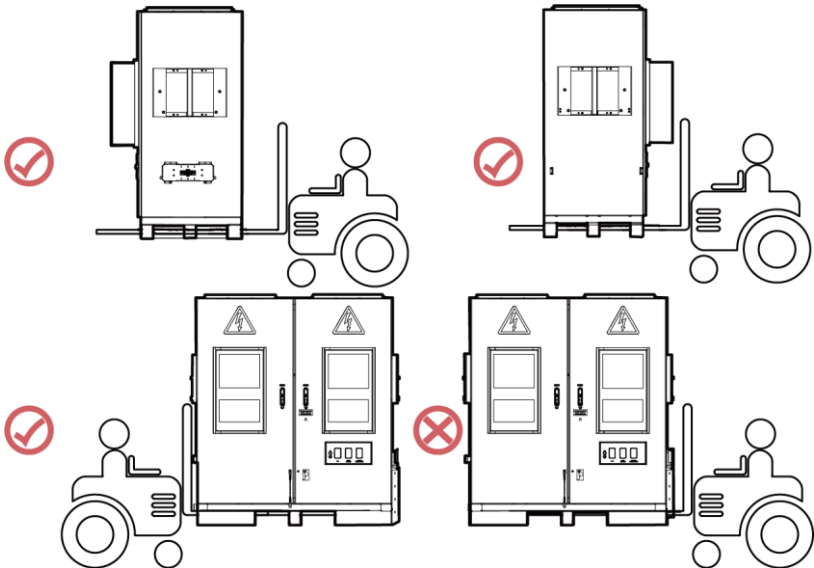

8. Secure the ESS.

NOTE

If the ESS is not positioned stably, use a spacer to level the ESS before securing it.

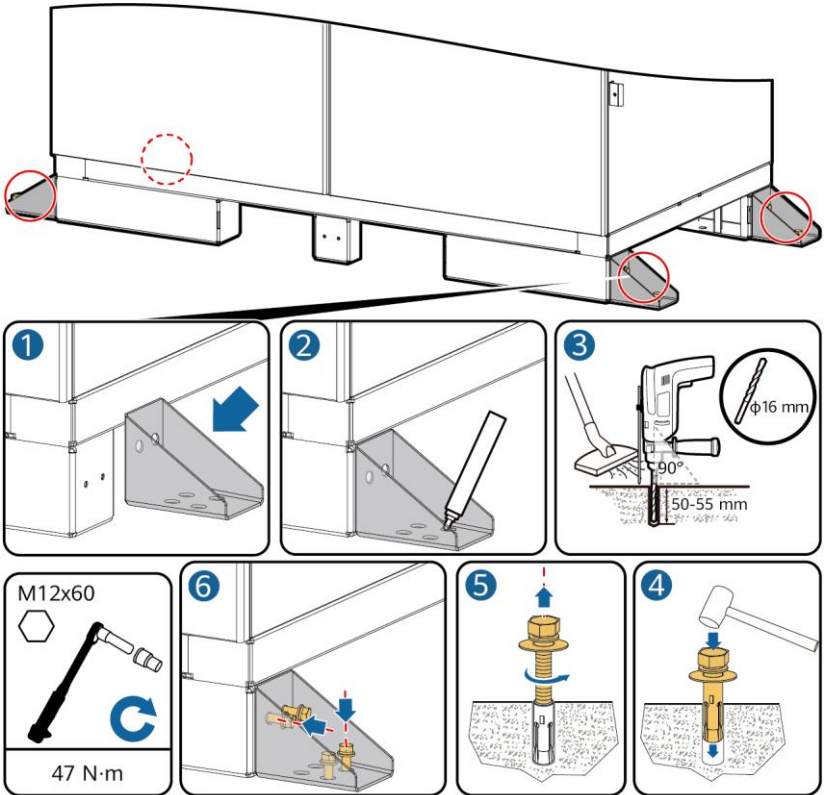

IB03H00001

4 Connecting a Ground Cable for the ESS

Name	Type	Conductor Cross-Sectional Area	Outer Diameter	Terminal	Source
Ground cable	Single-core outdoor copper/copper-clad aluminum/aluminum alloy cable	25–50 mm ²	15–17.6 mm	M8 OT/DT terminal	Prepared by the customer

The specifications of the ground cable are subject to this table or calculated according to IEC 60364-5-54.

Open the ESS cabinet doors and connect the ground cable.

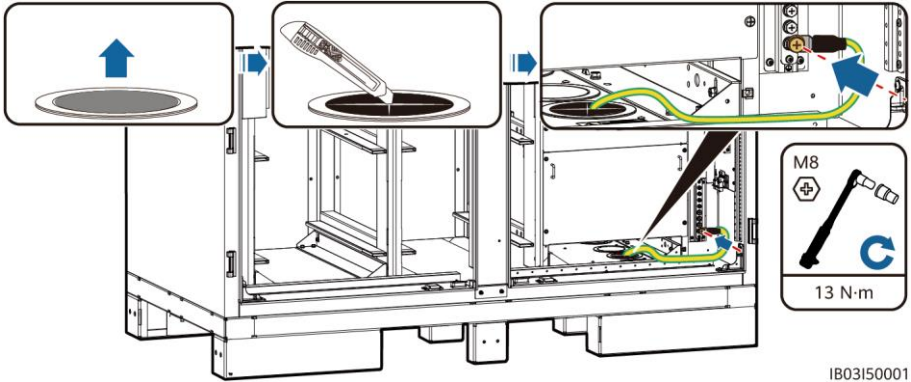

IB03150001

5 Installing Components

5.1 Installation Positions

NOTICE

Before installing components, ensure that the ESS is securely installed.

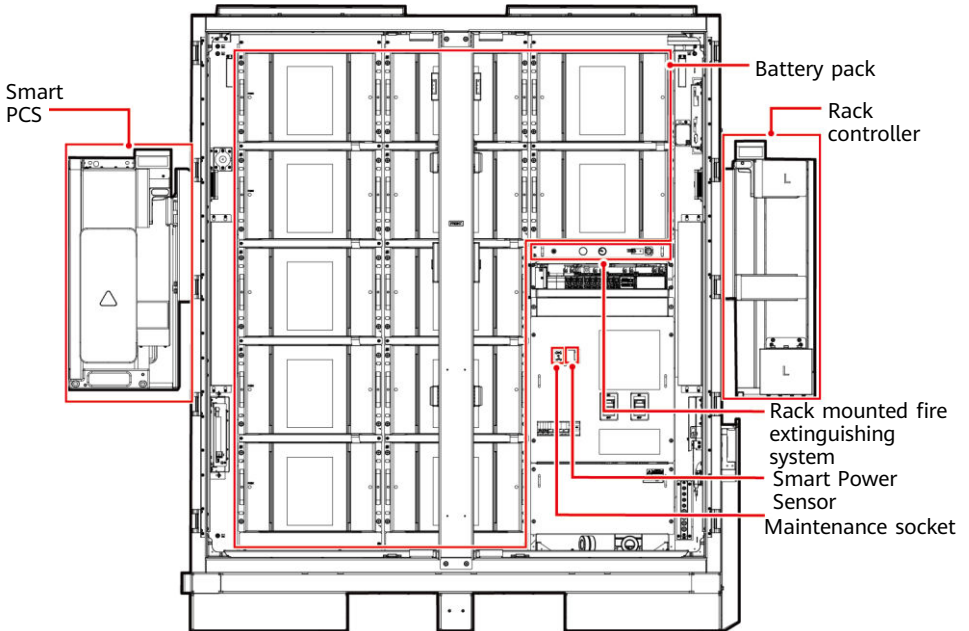

IB03W00028

No.	Component	Source	No.	Component	Source
1	Rack mounted fire extinguishing system	Purchased from the Company	4	Smart PCS	Purchased from the Company
2	Battery pack ^[1]	Purchased from the Company	5	(Optional) Maintenance socket	Prepared by the customer
3	Rack controller	Purchased from the Company	6	(Optional) Smart Power Sensor (DDSU666-H)	Purchased from the Company

Note [1]: Six dummy battery packs are preinstalled in the LUNA2000-97KWH-1H1 ESS, in which six battery packs are required.

Four dummy battery packs are preinstalled in the LUNA2000-129KWH-2H1 ESS, in which eight battery packs are required.

Two dummy battery packs are preinstalled in the LUNA2000-161KWH-2H1 ESS, in which ten battery packs are required.

Twelve battery packs are required in the LUNA2000-200KWH-2H1 ESS.

5.2 Installing the Rack Mounted Fire Extinguishing System

NOTE

Before installation, read the documents delivered with the rack mounted fire extinguishing system to understand the installation requirements and precautions.

Install the rack mounted fire extinguishing system.

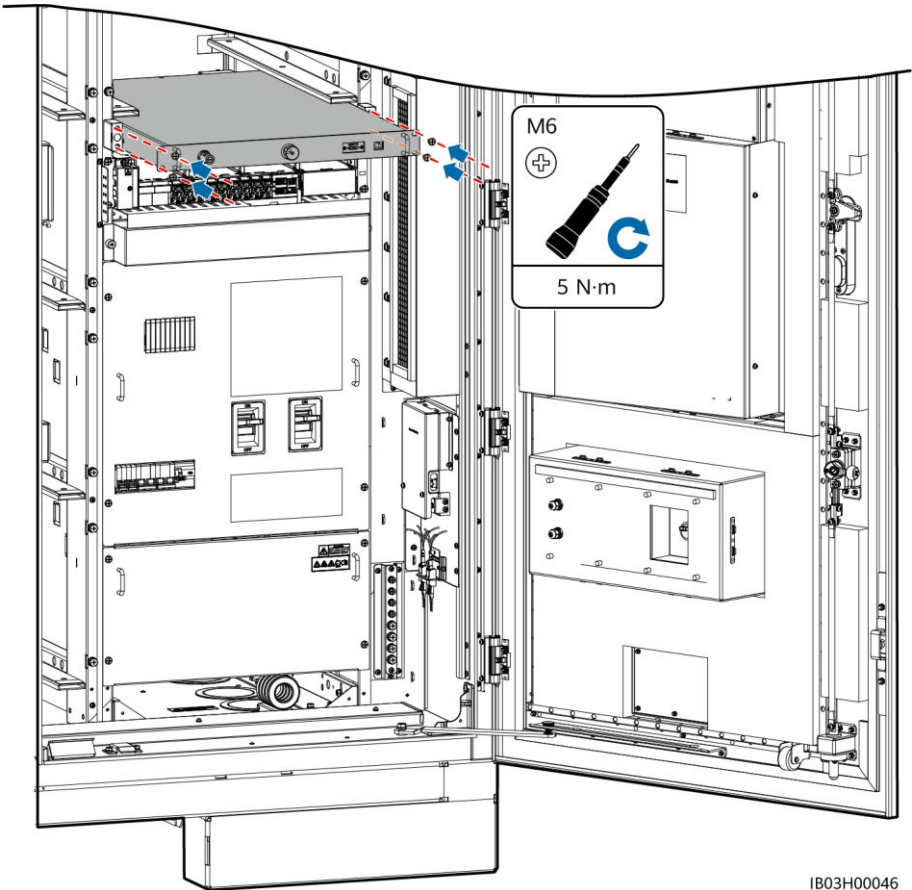

IB03H00046

5.3 Installing Battery Packs

NOTICE

- Before installation, ensure that battery packs are stored indoors and that other storage requirements specified in the user manual are met.
- Before installation, check the status of the battery packs. Do not use the battery packs if the packing cases are exposed to rain, damaged, or deformed, or if the battery packs leak or fall.
- Do not install battery packs on rainy, snowy, or foggy days. Otherwise, the battery packs may be eroded by moisture or rain.

1. Remove the column from the ESS.

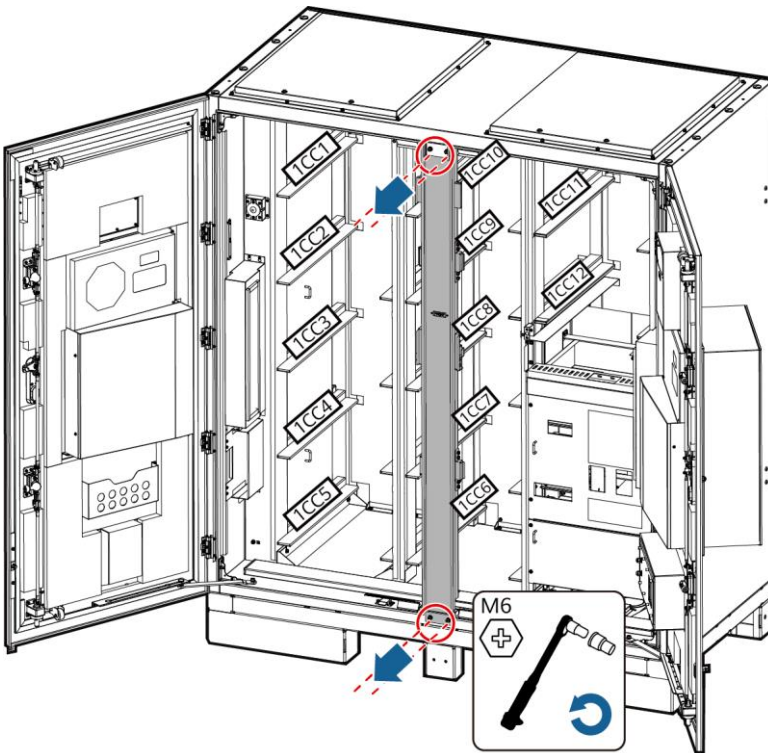

IB03H00036

2. Use a forklift to transport the battery installation tray kit (installation kit for short) to the vicinity of the ESS.

NOTE

The installation kit should be purchased from the Company.

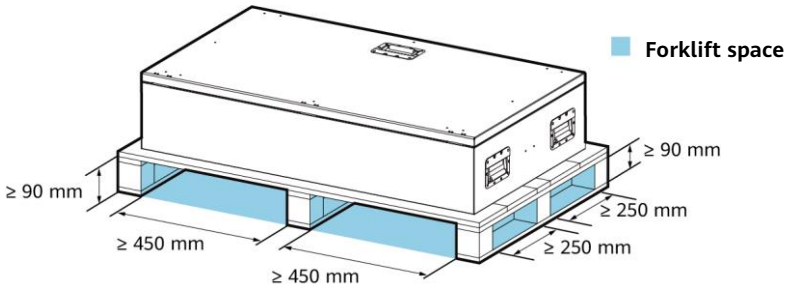

IB03W00016

3. Take out the installation kit.

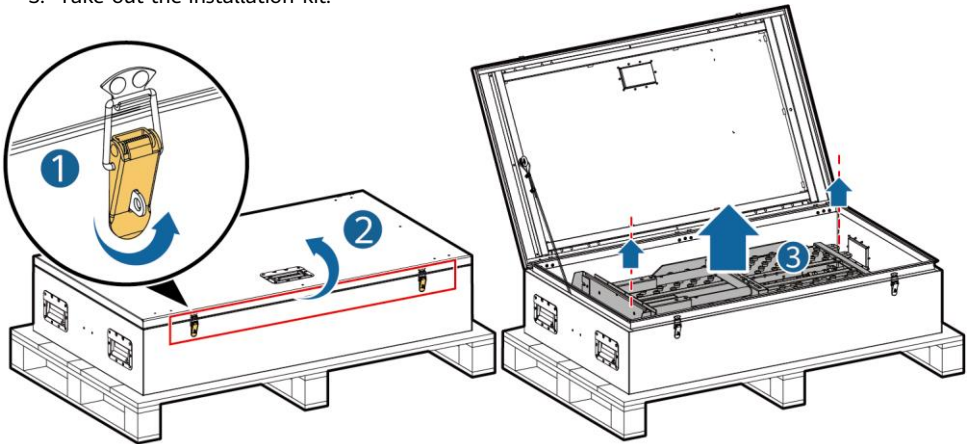

IB03H00024

4. Insert, assemble, and secure the installation kit onto the forklift.

NOTE

- Requirements for the lifting height of the forklift: If the foundation height is less than or equal to 0.3 m, the lifting height is greater than or equal to 2 m. If the foundation height is greater than 0.3 m, the lifting height increases accordingly.
- The load-bearing capacity of the forklift must be greater than or equal to 2 t.

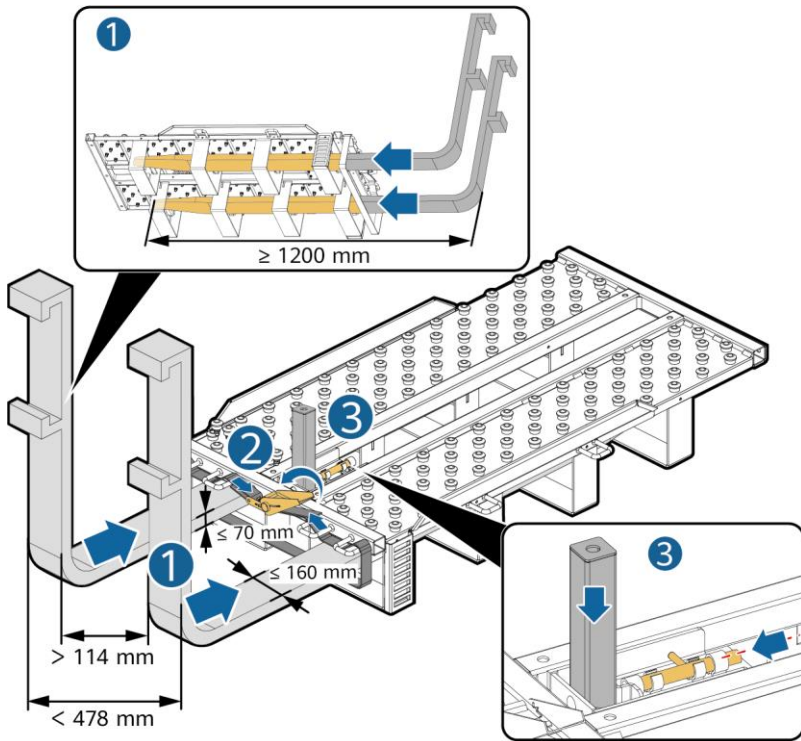

IB03H00030

5. Take out the battery pack.

NOTE

- At least four persons are required to move a battery pack.
- When using the lifting handles, hold the handle end closer to the device.

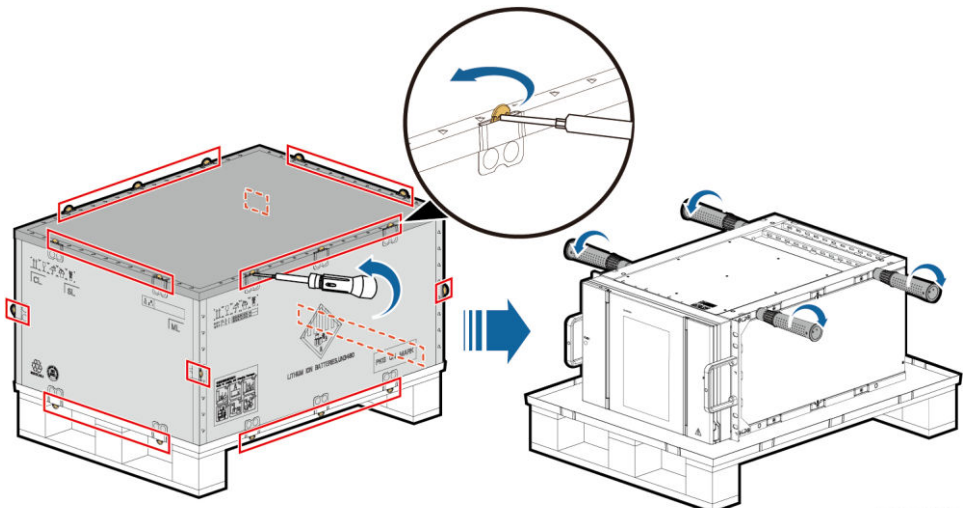

IB03H00031

NOTICE

- Secure the lifting handles (with the steel washers of the lifting handles closely fitted to the battery pack).
- If the stud of a lifting handle is bent, replace the lifting handle in time.

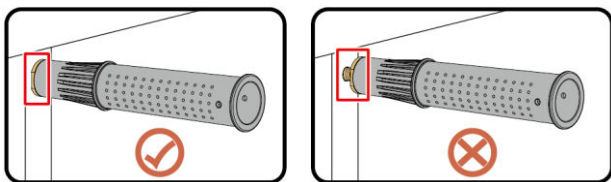

S000004

6. Install and secure the battery pack on the installation kit.

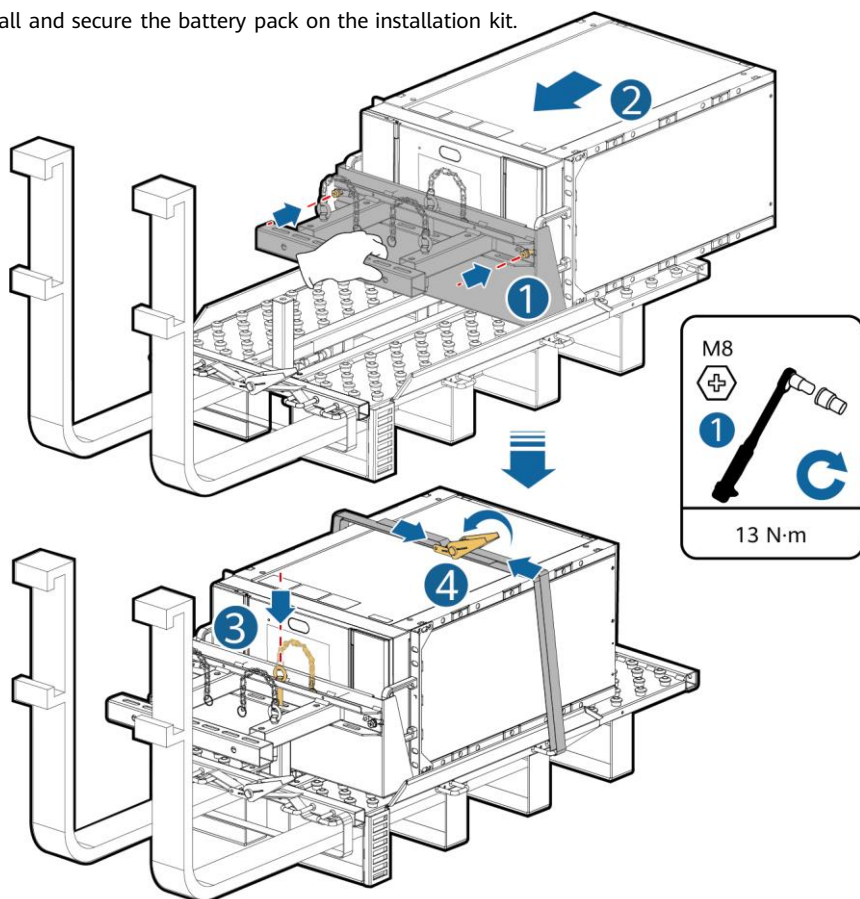

IB03H00023

7. Install the battery pack in the ESS.

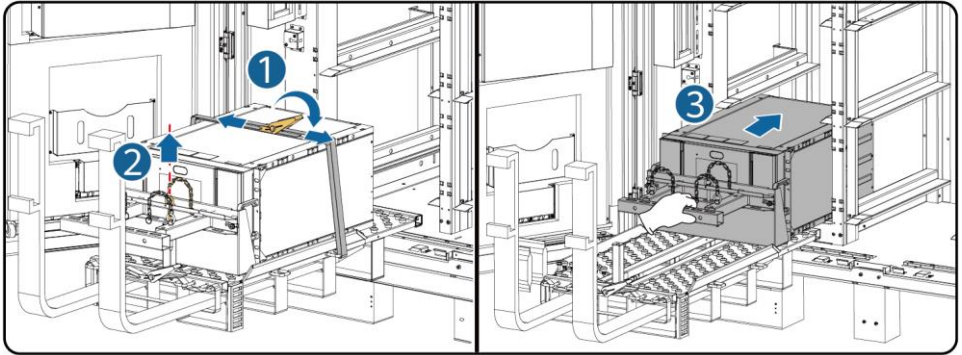

IB03H00025

8. Secure the battery pack using the delivered screws.

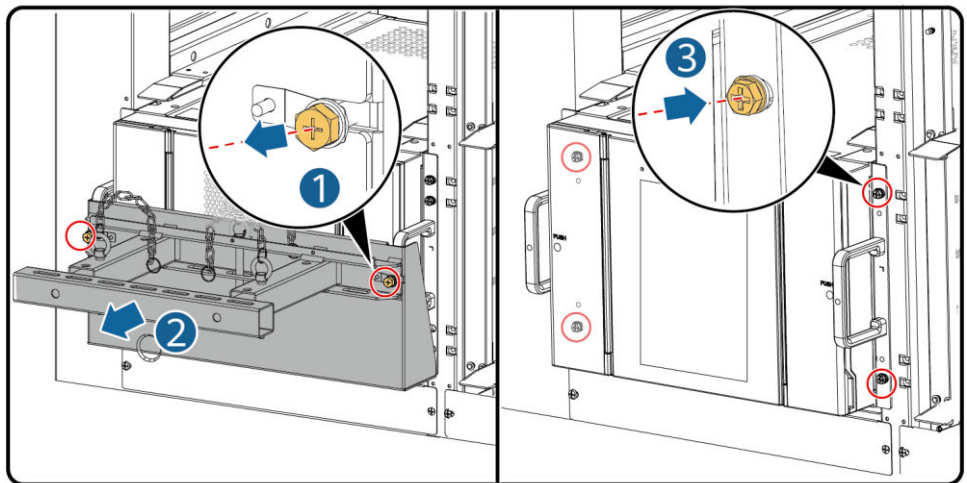
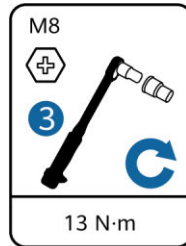

IB03H00026

NOTE

Dummy battery packs have been preinstalled in the 97 kWh, 129 kWh, and 161 kWh ESSs to separate air channels and must not be removed.

9. Install air channel plates between battery packs based on the labels on the air channel plates. The air channel plates are delivered with the product.

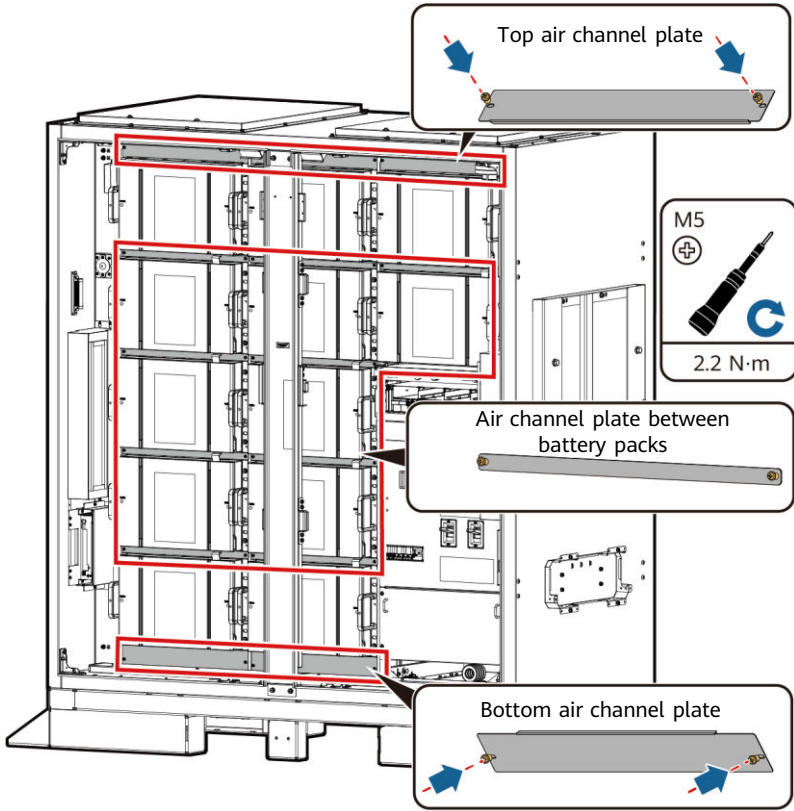

IB03H00041

10. Install the column to the ESS.

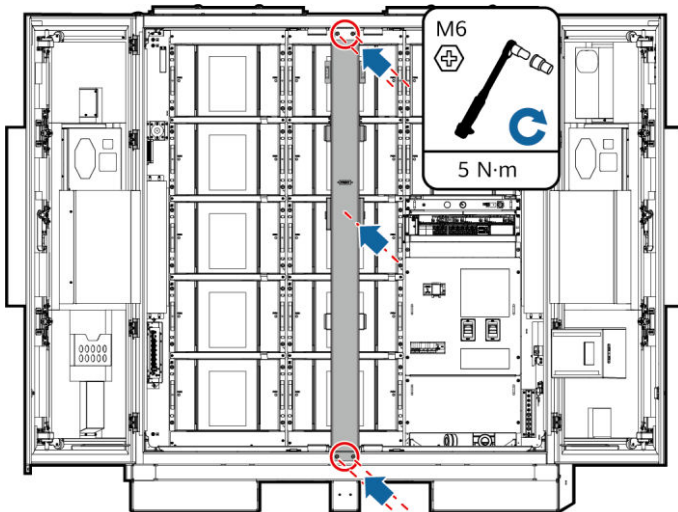

IB03H00037

5.4 Installing the Rack Controller

1. Remove the decorative cover and maintenance compartment cover from the rack controller using the delivered security Torx wrench.

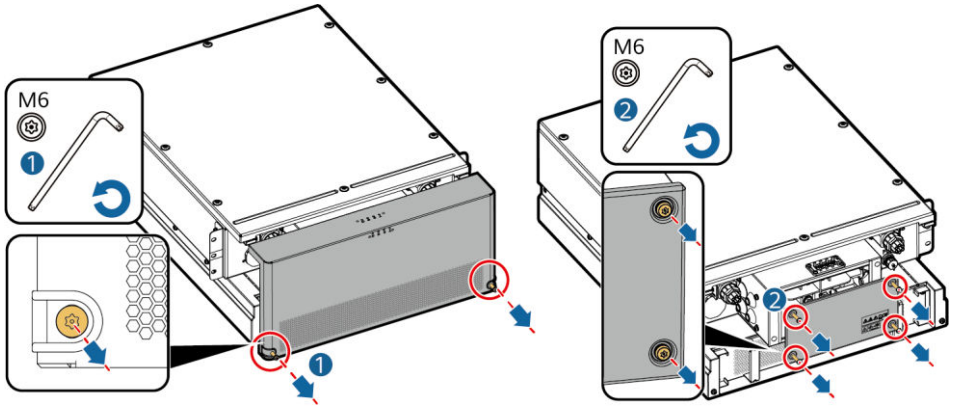

IB03H00016

2. Install short-circuiting copper bars that are delivered with the product.

NOTE

Secure the copper bars using a 16 mm socket.

200 kWh Model

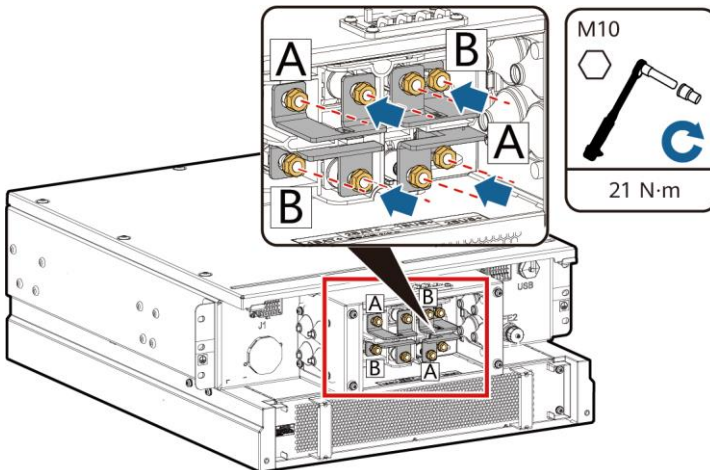

IB03H00019

97 kWh/129 kWh/161 kWh Model

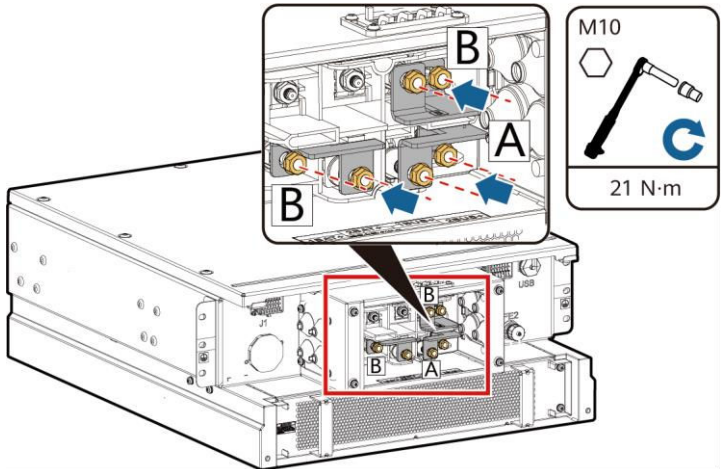

5000003

3. Install the decorative cover and maintenance compartment cover to the rack controller.

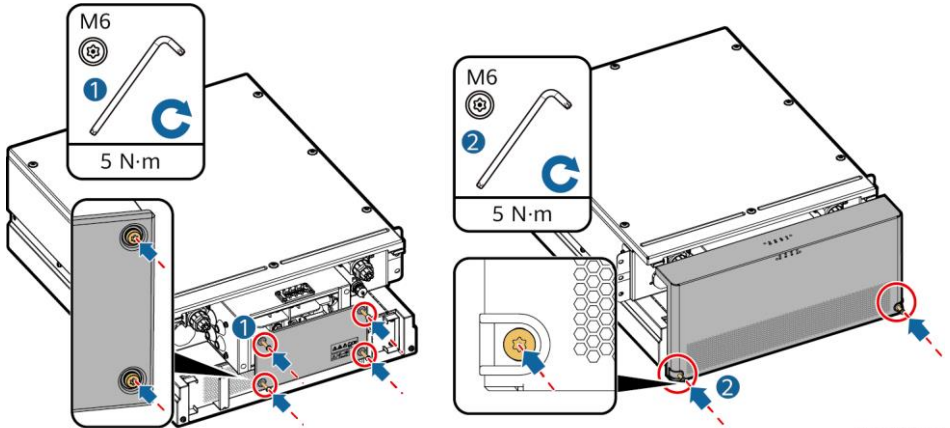

IB03H00032

4. Remove cables bound on the outside of the ESS.

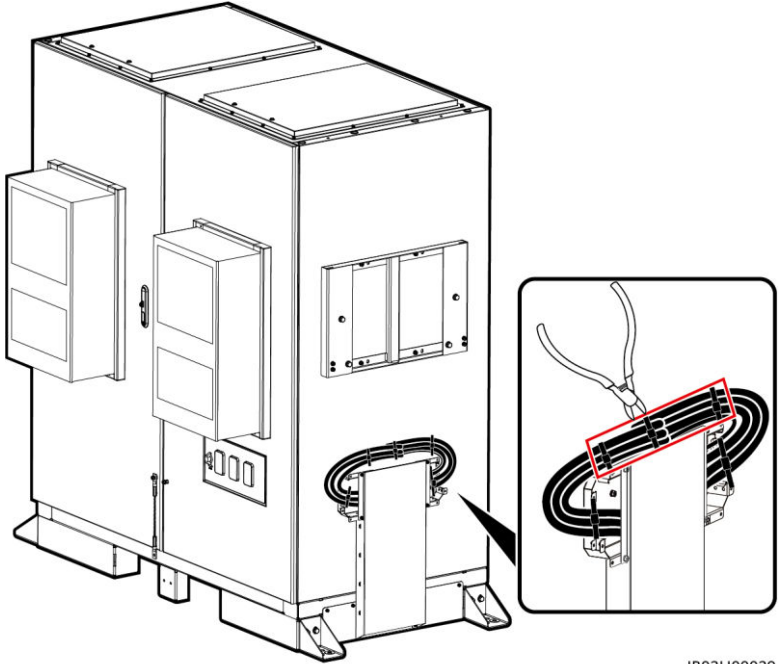

IB03H00039

5. Install the upper bracket, lower bracket, rainproof canopy, and lifting handles to the rack controller.

 NOTE

- The upper bracket, lower bracket, rainproof canopy, and lifting handles are delivered with the product.
- The screws for securing the upper and lower brackets are preinstalled on the rack controller. Remove the screws before installing the upper and lower brackets.
- The screws for securing the rainproof canopy are preinstalled on the upper bracket. Remove the screws before installing the rainproof canopy.
- When using the lifting handles, hold the handle end closer to the device.

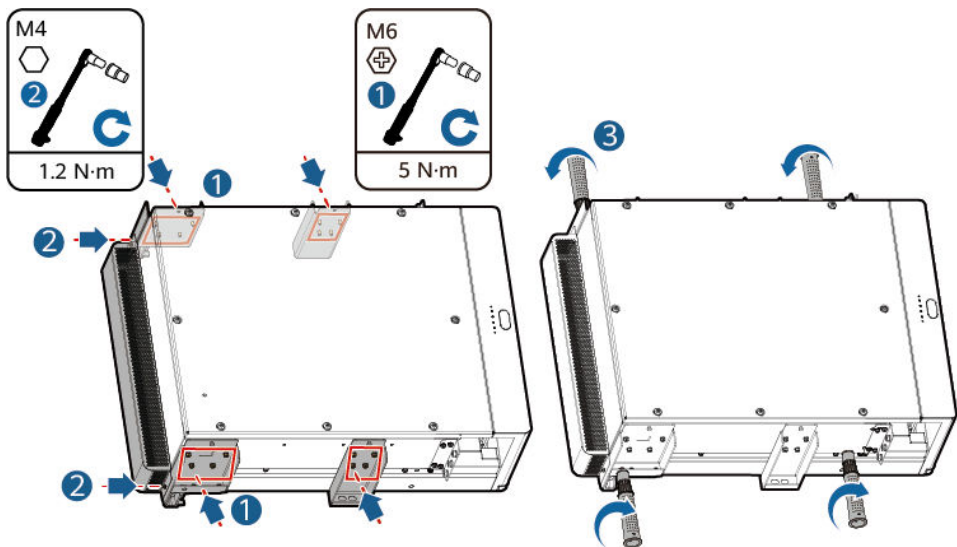

IB03H00018

6. Install the rack controller to the mounting bracket on the ESS.

NOTE

- The M8 screws are used to secure the rack controller. Keep them properly after removing them.
- At least three persons are required to install the rack controller.

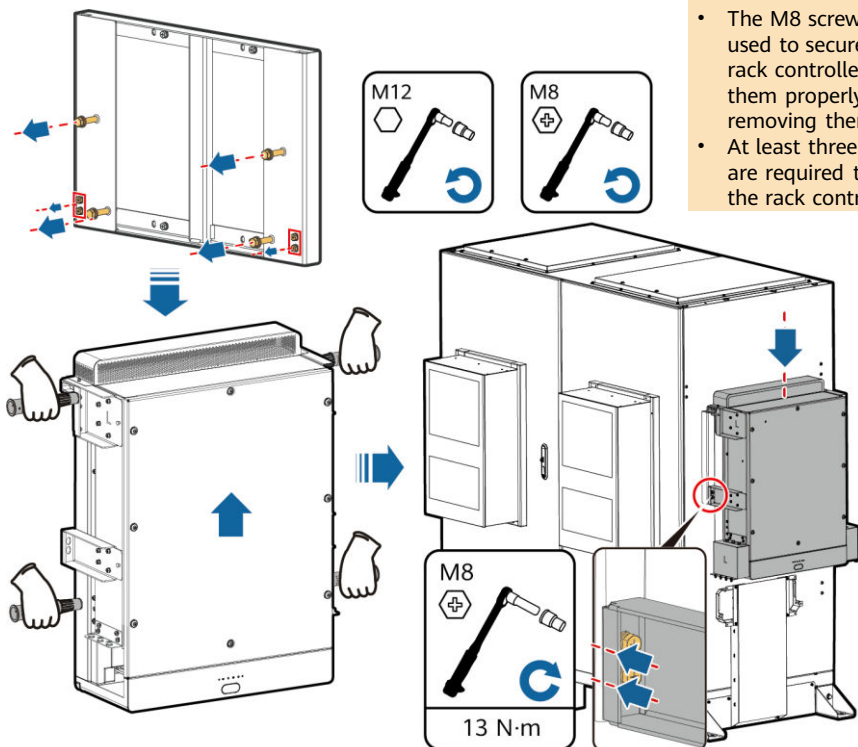

IB03H00035

5.5 Installing the Smart PCS

1. Install the mounting bracket.

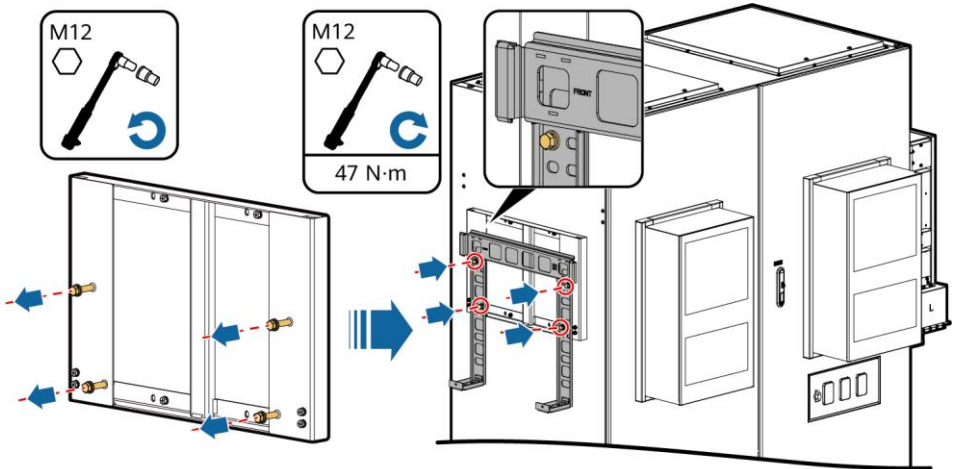

IB02H0044

2. Install mounting ears and lifting handles, and then secure the Smart PCS. The mounting ears are delivered with the Smart PCS, and the lifting handles are delivered with the ESS.

NOTE

- At least four persons are required to install the Smart PCS.
- When using the lifting handles, hold the handle end closer to the device.

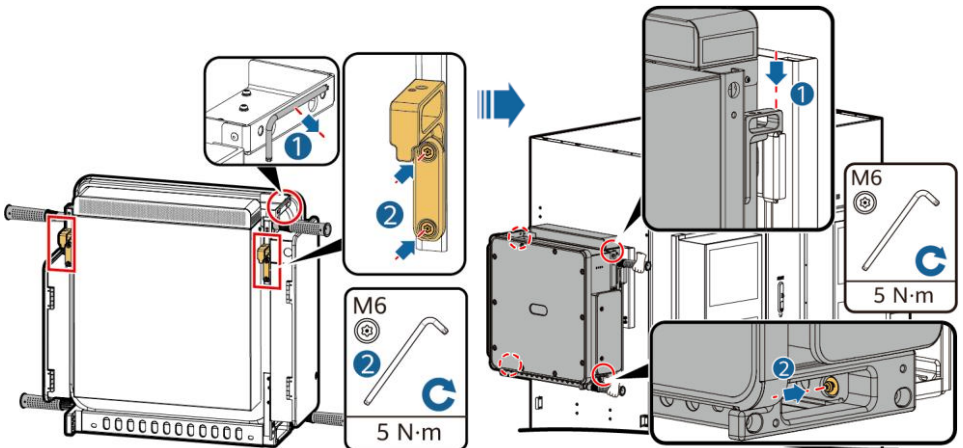

IB02H0025

IB02H0028

5.6 (Optional) Installing the Maintenance Socket

NOTE

The 220 V socket is prepared by the customer. The actual socket appearance may vary. This guide describes only the installation method.

1. Remove the baffle plate in front of the power distribution area.
2. Install the maintenance socket.

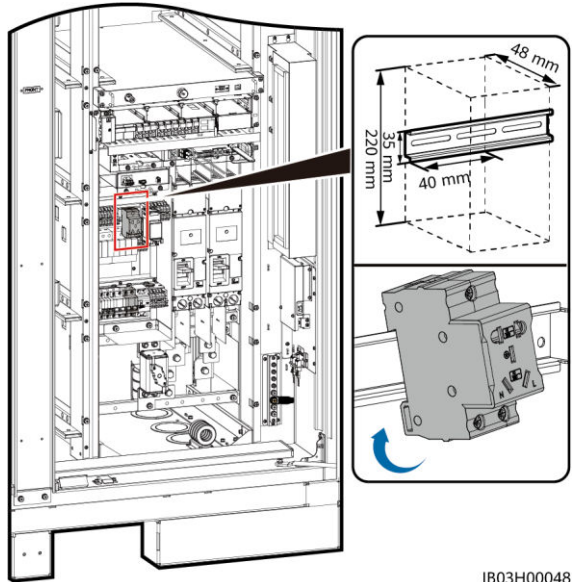

IB03H00048

5.7 (Optional) Installing the Smart Power Sensor (DDSU666-H)

1. Remove the baffle plate in front of the power distribution area.
2. Install the DDSU666-H.

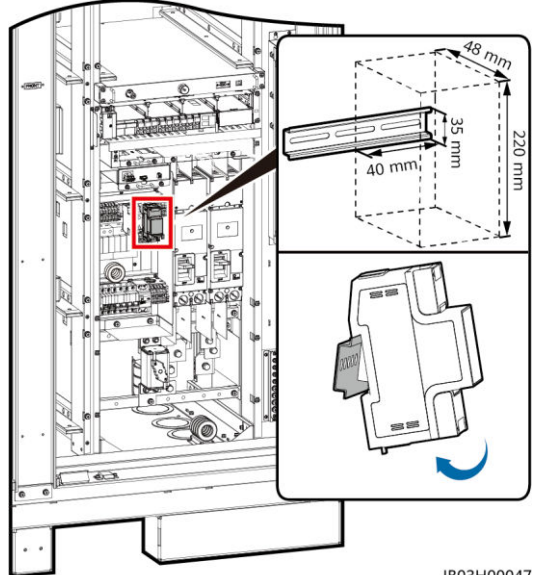

IB03H00047

6 Installing Cables

6.1 Preparing Cables

NOTE

The cable diameter must comply with local cable standards. The key factors include the rated current, cable type, routing method, maximum expected line loss, rated temperature, ambient temperature, thermal resistance, acidity, sedimentation, and environmental protection requirements.

Name	Type	Conductor Cross-Sectional Area	Outer Diameter	Terminal	Source
Ground cable for the rack controller	Single-core outdoor copper cable	≥ 25 mm ²	-	M6 OT/DT terminal	Prepared by the customer
DC power cable	Prefabricated DC power cable (with a corrugated pipe)	-	-	-	Delivered with the product
Auxiliary AC power cable (with external grid power supply)	Two-core (L, N)/Three-core (L, N, PE) outdoor copper/copper-clad aluminum/aluminum alloy cable	6–25 mm ²	12.7–27 mm	Cord end terminal with an insertion depth of 12 mm, M8 OT/DT terminal	Prepared by the customer
Single-phase AC input power cable (without external grid power supply)	Two-core/Three-core outdoor copper/copper-clad aluminum/aluminum alloy cable	6–25 mm ²	12.7–27 mm	Pin cord end terminal with an insertion depth of 12 mm	Prepared by the customer
Network cable	CAT 5E outdoor shielded network cable, internal resistance ≤ 1.5 ohms/10 m	-	≤ 9 mm	Shielded RJ45 connector	Prepared by the customer
Optical fiber cable	Four-core or eight-core single-mode armored cable with the transmission wavelength of 1310 nm	-	≤ 18 mm	-	Prepared by the customer
(Optional) Cable to the DDSU666-H	RS485 communications cable	-	-	-	Preinstalled before delivery
	Current transformer cable, and power cable	-	-	-	Delivered with the product
(Optional) Cable to the maintenance socket	Power cable and ground cable	-	-	-	Delivered with the product

6.2 Installing Cables for the Rack Mounted Fire Extinguishing System

Take out the reserved cables and install them to the rack mounted fire extinguishing system.

WARNING

Ensure that the cables are correctly installed. If a fire occurs when cables are not connected or incorrectly connected, the ESS cannot actively extinguish the fire.

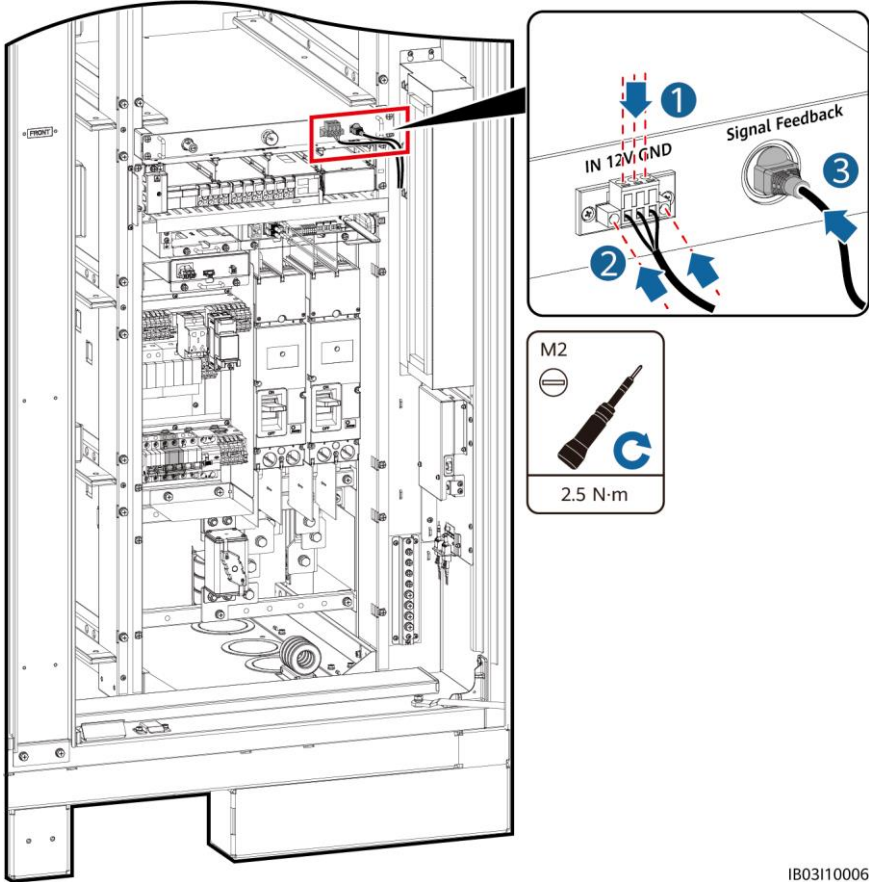

IB03110006

6.3 Installing Battery Pack Cables

1. Install copper bars for battery packs, and connect the battery rack general output power cable and black start cable.

NOTE

- One ends of the battery rack general output power cable and black start cable are preinstalled before delivery.
- There are four types of copper bars delivered with the product: A, B, C, and D.
- Copper bar D must be installed before copper bar B.
- There are two types of M10 nuts for securing copper bars. Select a 15 mm or 16 mm socket based on the site requirements.
- When installing a nut, manually insert the nut into the screw plate, and then use a socket wrench to completely secure the nut in place. This prevents the screw thread from being stuck or stripped due to the deviation of the nut position.
- Preinstall nuts according to the recommended torque of 27 N·m.
- Verify the torque of the installed nuts using a torque socket wrench set to 27 N·m.
- Mark the nuts whose torque has been verified using a marker.

200 kWh Model

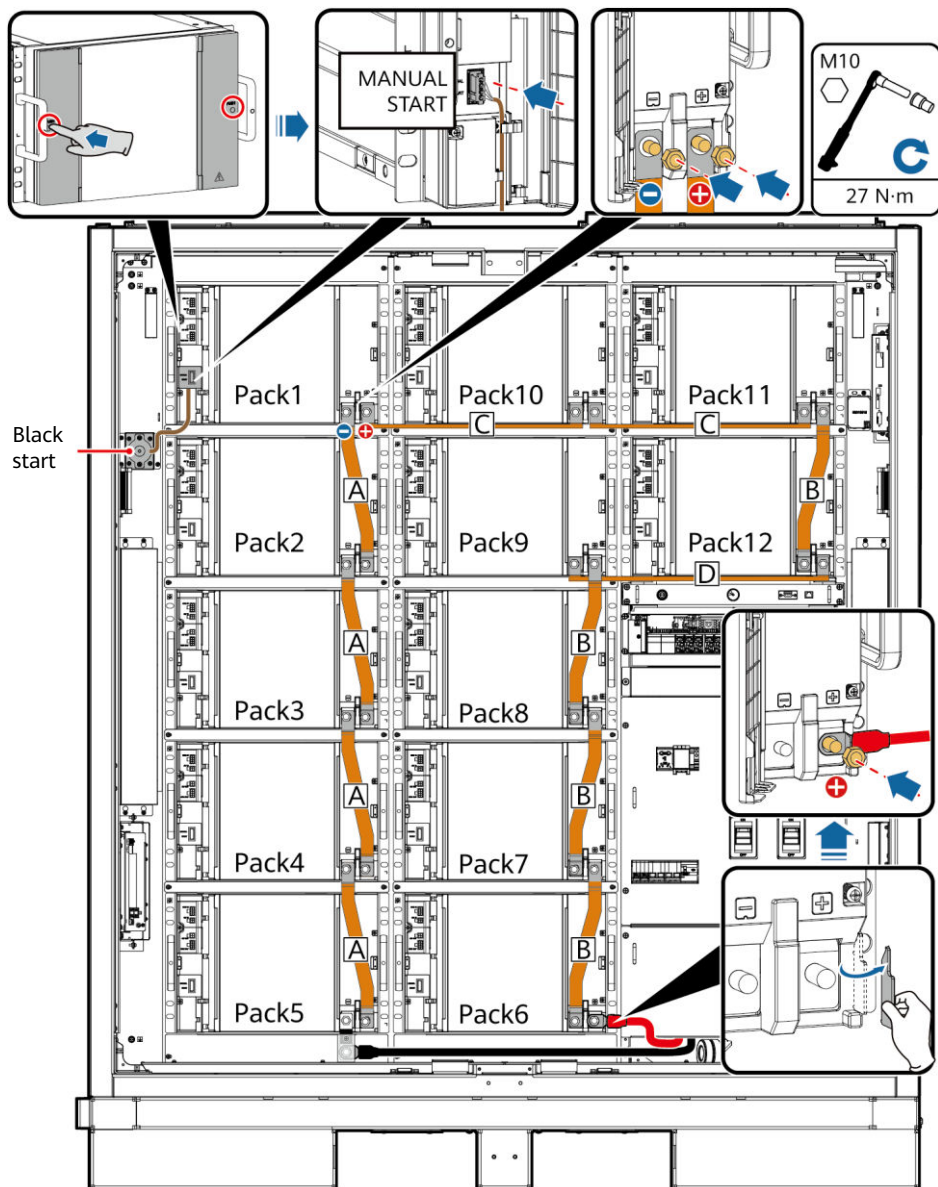

IB03H00040

NOTE

- No copper bar is required for the preinstalled dummy battery packs of 97 kWh, 129 kWh, and 161 kWh models.
- Keep the redundant copper bars of the 97 kWh, 129 kWh, and 161 kWh models properly for later use.

161 kWh Model

NOTE

Connect the black start cable to Pack1.

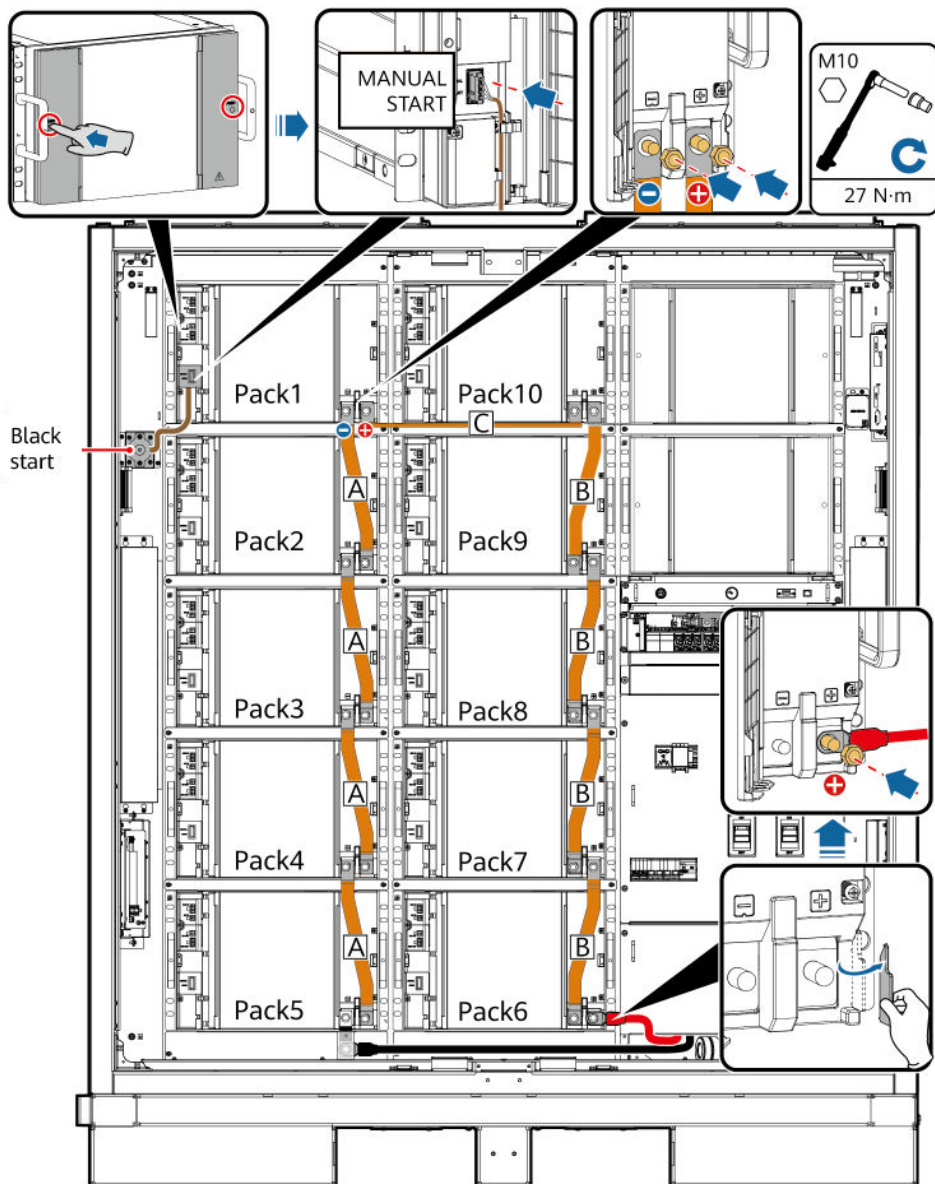

129 kWh Model

NOTE

Connect the black start cable to Pack2.

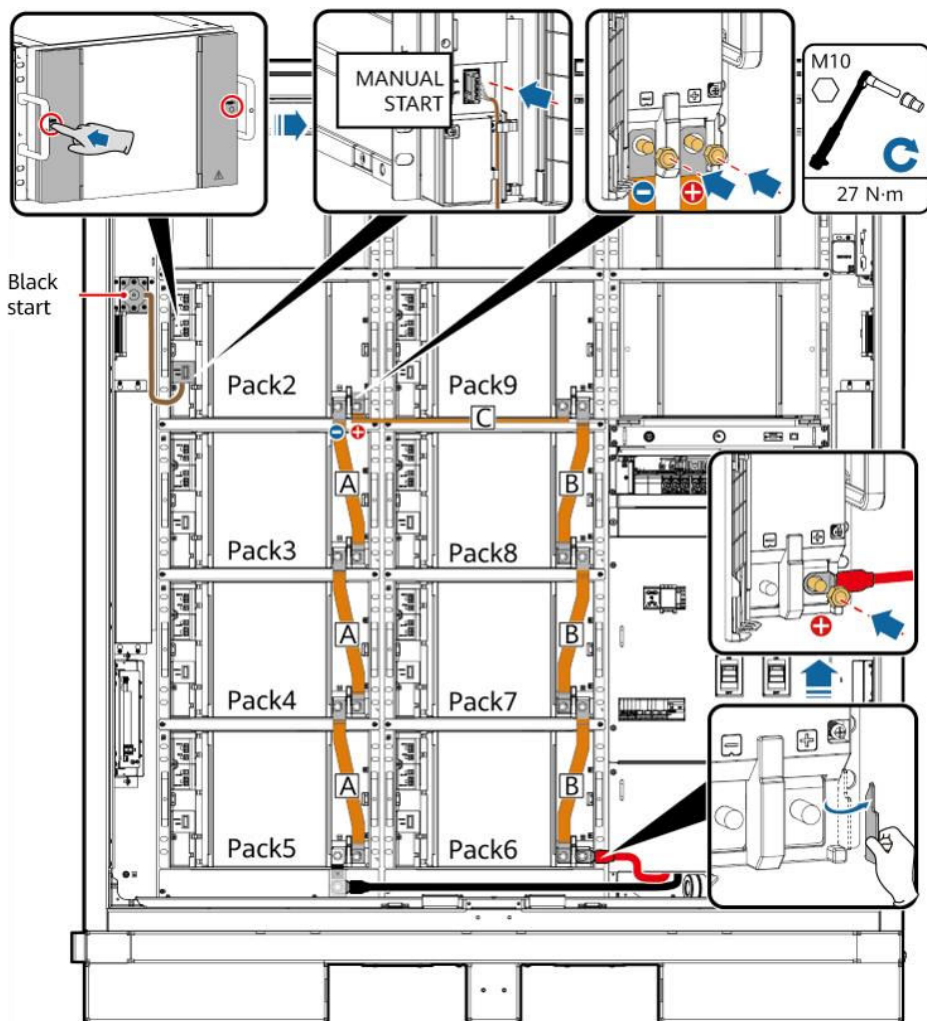

97 kWh Model

NOTE

Connect the black start cable to Pack3.

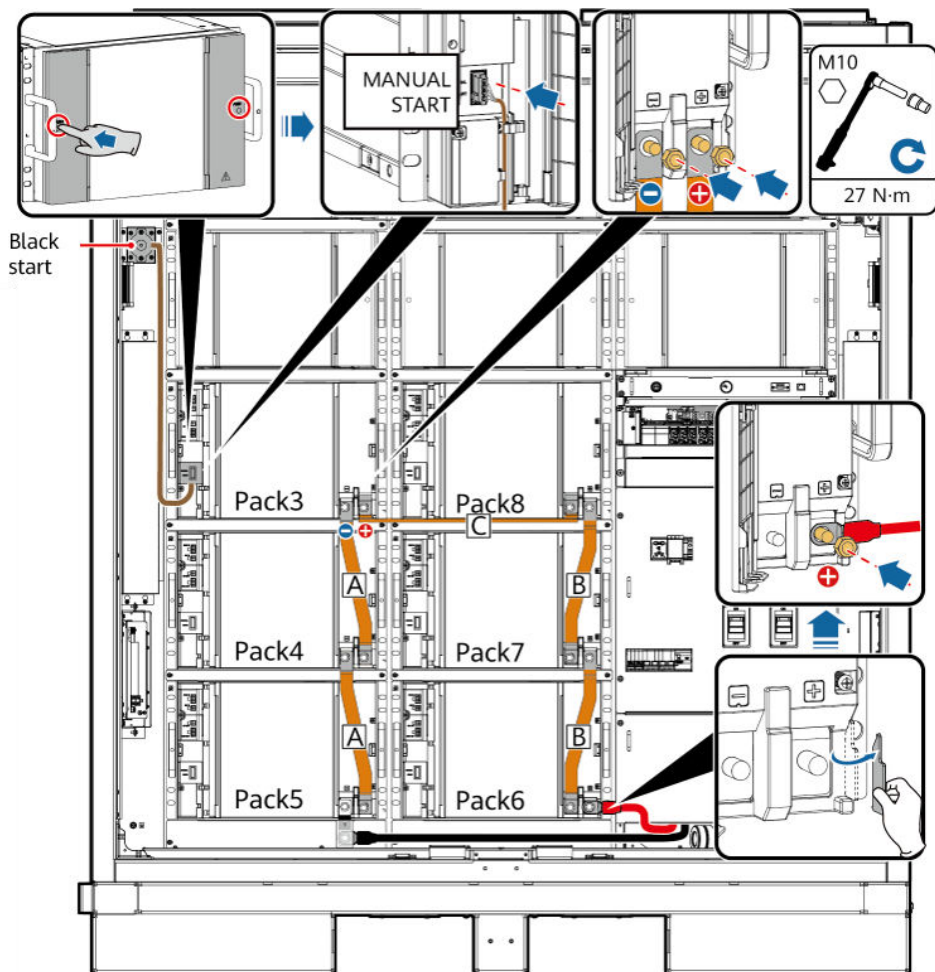

2. Install the 48 V cables.

NOTE

- The 48 V cables of all models are connected in the same way.
- Cables to 2FCB6 and 2FCB7 are preinstalled before delivery.
- Other 48 V cables are delivered with the product.
- The cable between Pack10 and Pack11 is 04097837-10 or 04098675-10, and the other cables are 04097837-07 or 04098675-07.
- The cable sequence is as follows: 2FCB6-Pack1-2-3-4-5, 2FCB7-Pack12-11-10-9-8-7-6.
- Keep redundant cables properly for later use.

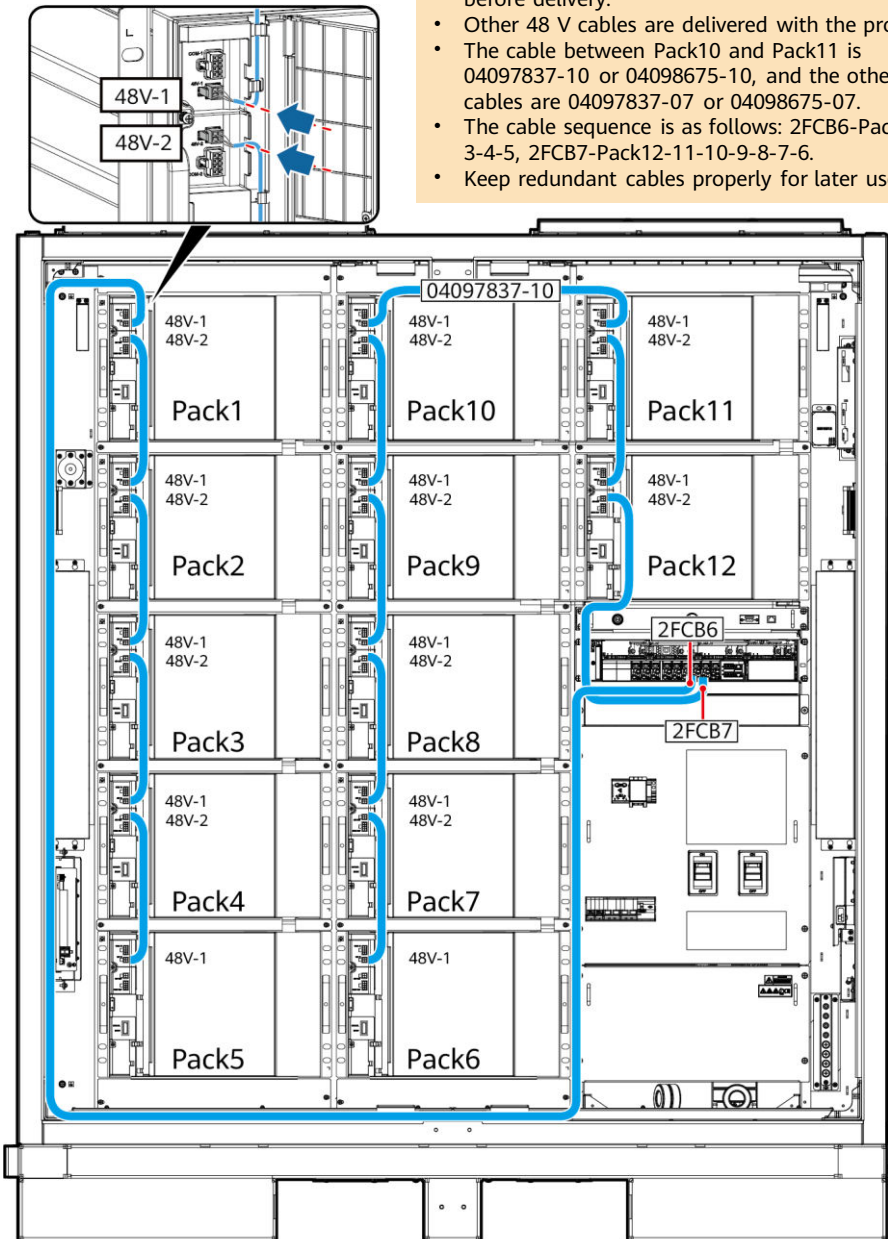

3. Install cables to the COM ports.

4. Close the terminal covers of the battery packs.

NOTE

- The COM cables of all models are connected in the same way.
- Cables to COM-1 on Pack1 and COM-2 on Pack12 are reserved before delivery. After connecting the cables to the battery packs, bind the cables inside the cabinet. Connect the other ends of the cables after installing the rack controller.
- Other COM port cables are delivered with the product.
- The cable sequence is as follows: Pack1-2-3-4-5-6-7-8-9-10-11-12.
- The cable between Pack5 and Pack6 is 04097837-08 or 04098675-08, the cable between Pack10 and Pack11 is 04097837-09 or 04098675-09, and the other cables are 04097837-06 or 04098675-06.
- Keep redundant cables properly for later use.

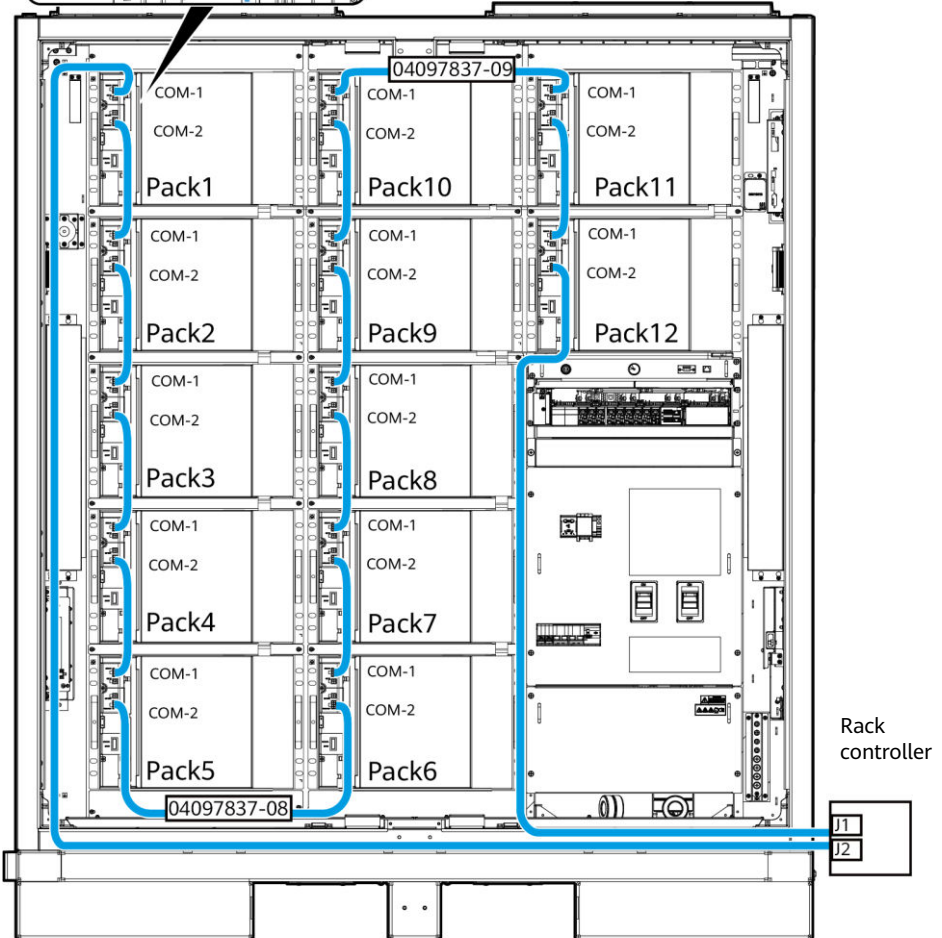
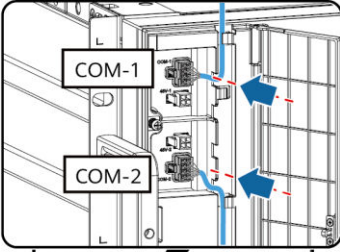

6.4 Installing Rack Controller Cables

1. Remove the decorative cover and maintenance compartment cover from the rack controller using the delivered security Torx wrench.

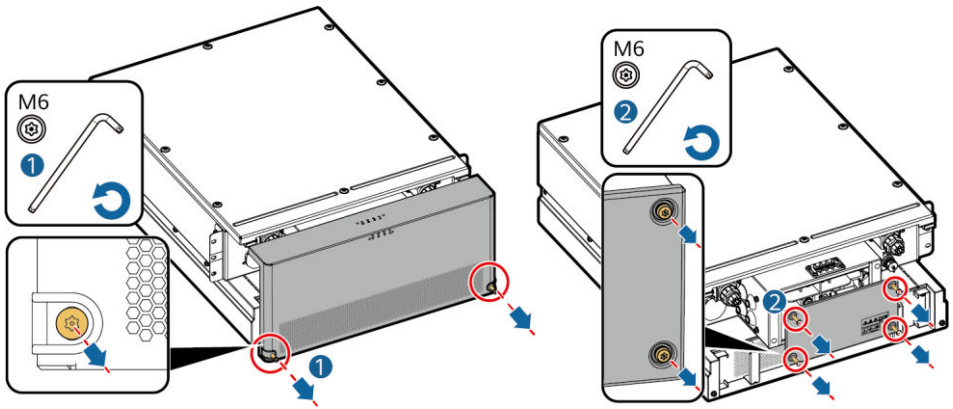

IB03H00016

2. Connect the preinstalled cables to the BAT/BUS ports. Magnetic rings are delivered with the product and need to be bound after being installed.

NOTICE

- The black magnetic ring is installed on the left side of the rack controller, and the green magnetic ring is installed on the right side of the rack controller.
- Do not remove the cover from an unused pagoda connector.

200 kWh Model

Cable Label (Left)	Wiring Terminal	Cable Label (Right)	Wiring Terminal
107-1F1:2>TA1:2BAT+	2BAT+	108-1Q2:1>TA1:1BUS+	1BUS+
109-1Q1:4>TA1:2BAT-	2BAT-	111-1Q2:3>TA1:1BUS-	1BUS-

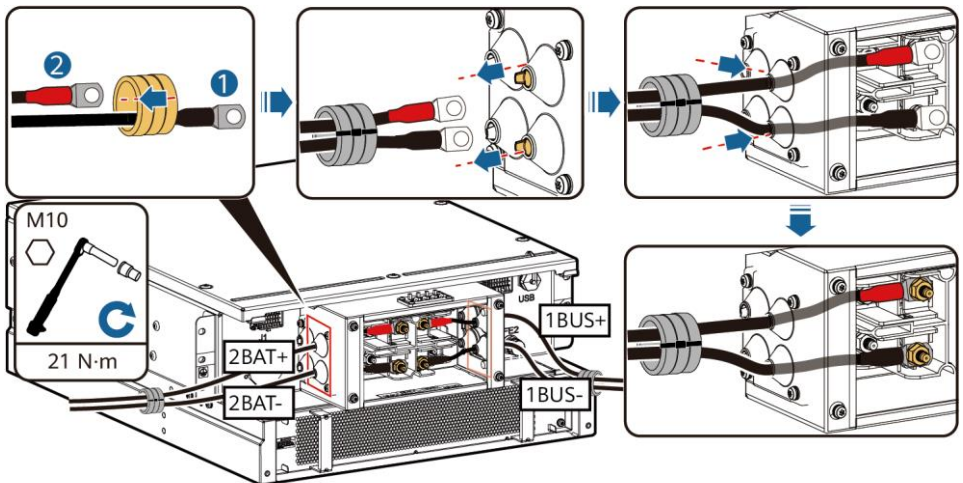

IB03I10002

97 kWh/129 kWh/161 kWh Model

Cable Label (Left)	Wiring Terminal	Cable Label (Right)	Wiring Terminal
107-1F1:2>TA1:2BAT+	2BAT+	108-1Q2:1>TA1:1BUS+	1BUS+
110-1F2:2>TA1:1BAT+	1BAT+	111-1Q2:3>TA1:1BUS-	1BUS-
109-1Q1:4>TA1:2BAT-	2BAT-	-	-

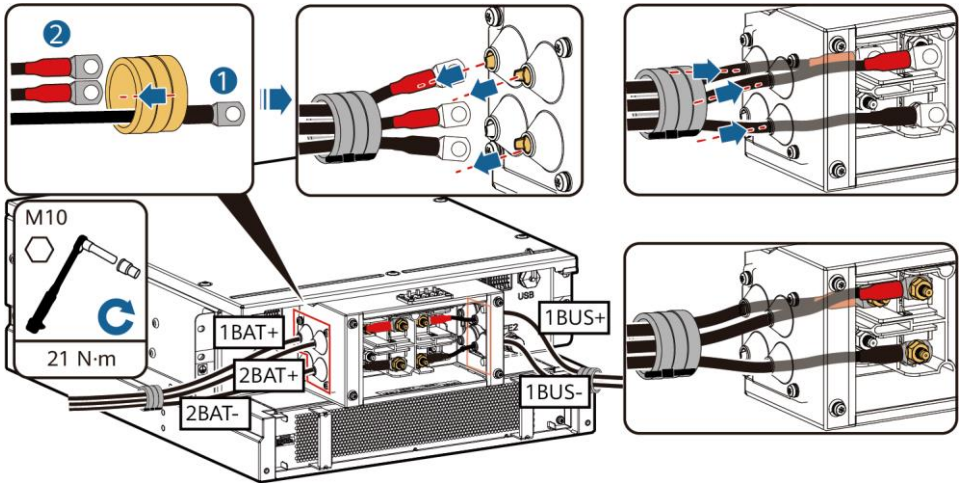

3. Connect the preinstalled cables to J1 (left), J2 (right), and FE1.

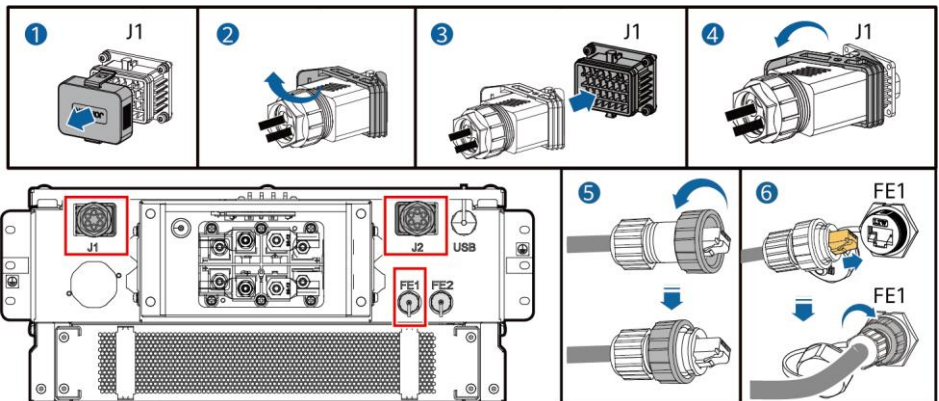

1B03140001

NOTE

- When securing the network cable (as shown by ⑥ in the figure), hold the cable and align it with the FE network port. After the network cable is properly installed, do not release it. Use the other hand to tighten the nut of the RJ45 connector.
- After the network cable is installed, gently pull it down to check that it is properly installed.

4. Install the maintenance compartment cover and decorative cover of the rack controller, and place the magnetic rings.

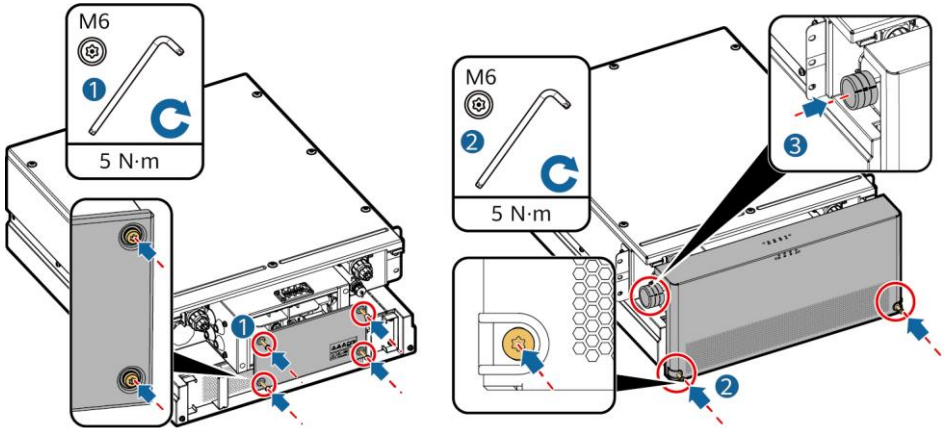

IB03H00020

5. Install the protective covers delivered with the product, connect a ground cable to the protective cover on the left or right side, and bind the cable.

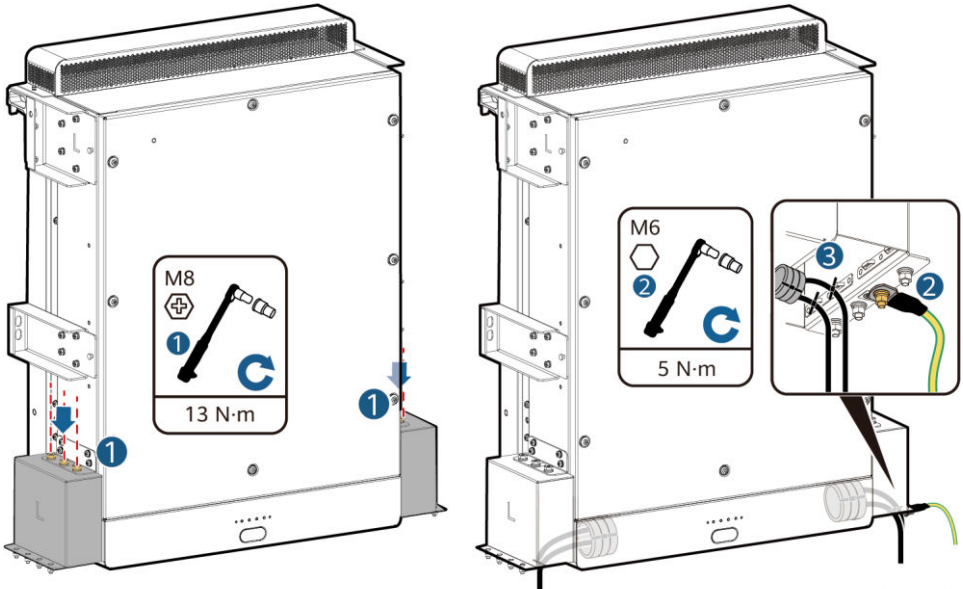

IB03H00022

6.5 Installing DC Power Cables

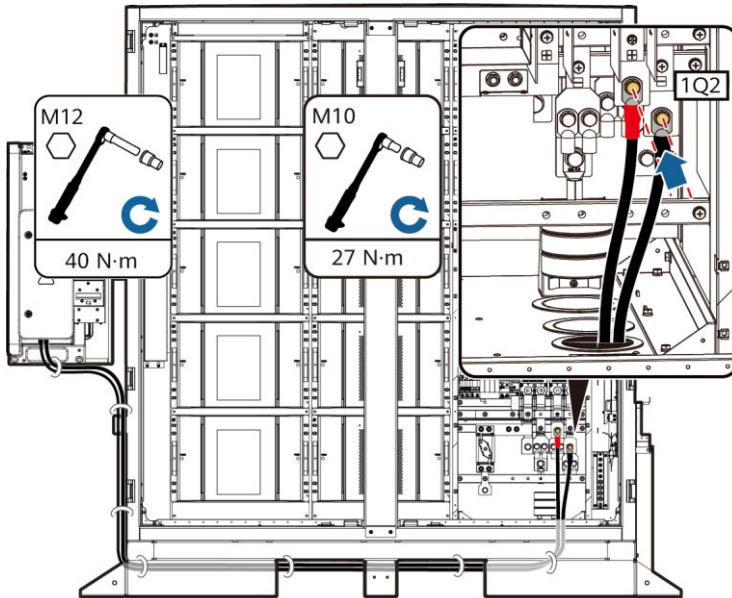

IB03130002

NOTE

- The prefabricated DC power cables are delivered with the product. The terminals at two ends of a DC power cable are applicable to M10 and M12 screws respectively. Connect the M10 terminal to the DC circuit breaker 1Q2 in the cabinet, and connect the M12 terminal to the DC side of the Smart PCS.
- Secure cables on the 1Q2 side using a 16 mm socket.
- For details about how to install other cables for the Smart PCS, see the corresponding quick guide.

6.6 Installing an Auxiliary AC Power Cable (with External Grid Power Supply)

NOTICE

Obtain the AC auxiliary power from the mains or a reliable power supply. Do not directly obtain power from the AC side of renewable energy inverters such as PV inverters and wind power converters.

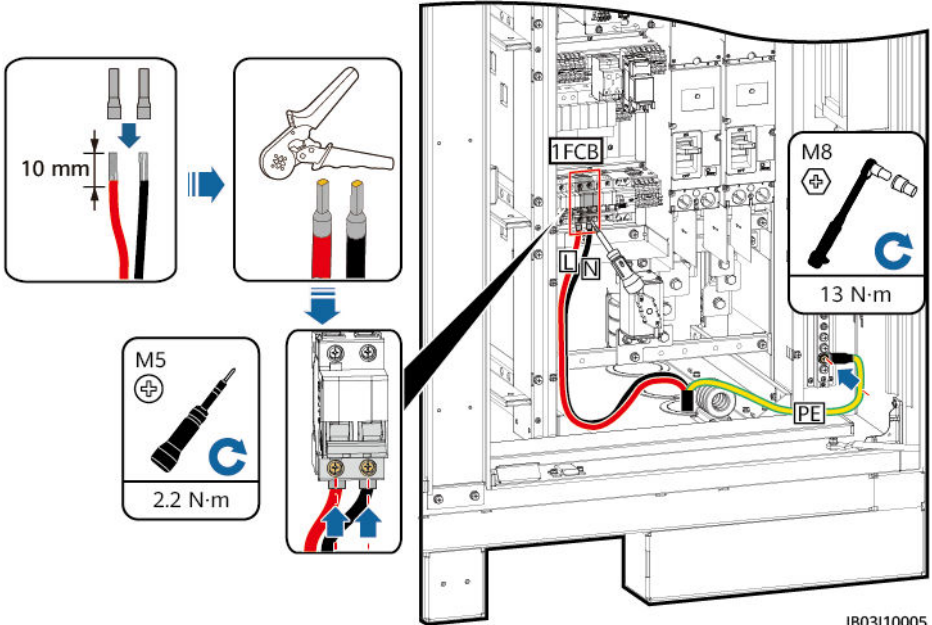

6.7 Installing a Single-Phase AC Input Power Cable (Without External Grid Power Supply)

NOTICE

Obtain the AC auxiliary power from the mains or a reliable power supply. Do not directly obtain power from the AC side of renewable energy inverters such as PV inverters and wind power converters.

NOTE

- If a UPS or other reliable backup power supply is used, perform the following steps to connect a single-phase AC input power cable.
- Recommended UPS input switch specifications: 230/400 V AC 32 A/2P.

1. Remove the short-circuiting bar from 1-2 and insert it to 2-3 on the XU terminal block.
2. Remove the short-circuiting bar from 4-5 and insert it to 5-6 on the XU terminal block.
3. Connect the cable.

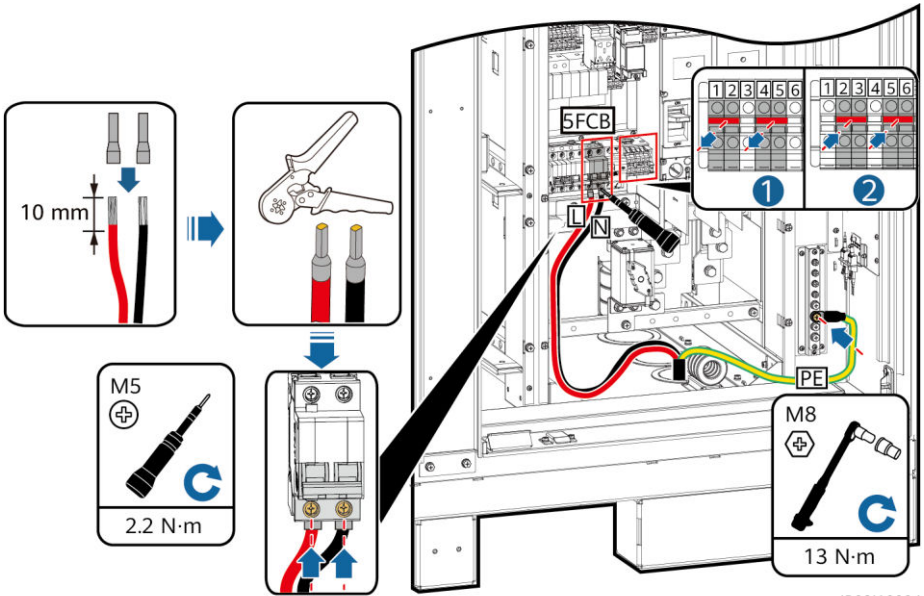

IB03110004

6.8 Installing Communications Cables

Installing an FE Communications Cable

Connect the FE communications cable to the WAN port on the CMU.

NOTICE

The communications cable needs to be routed through the magnetic ring at the cable hole at the bottom.

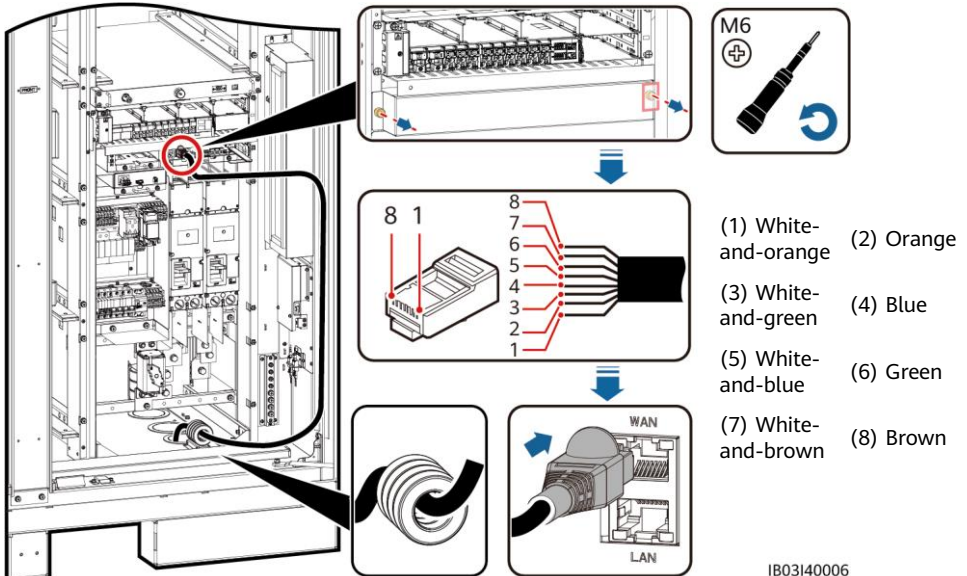

IB03140006

Installing Fiber Ring Network Communications Cables

NOTICE

- Only professionals are allowed to connect and splice optical fiber cables.
- In the optical fiber ring topology, two optical fiber cables are required.

1. Remove the external mechanical parts from the access terminal box (ATB).

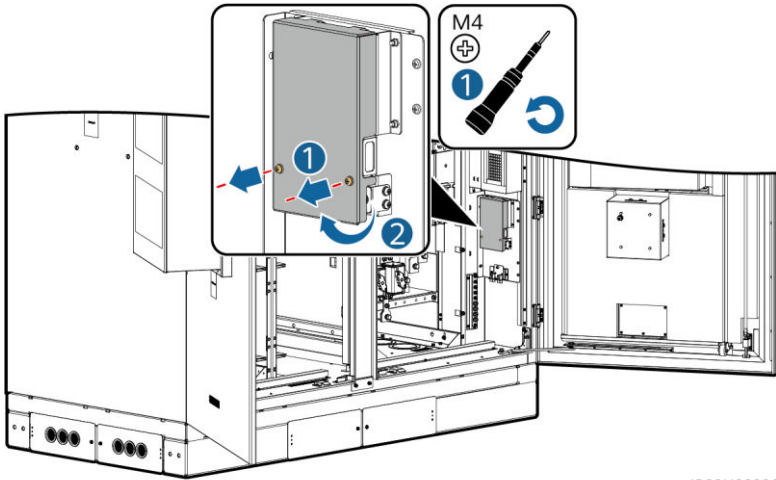

IB03H0006

2. Remove the optical fiber cable fastener.

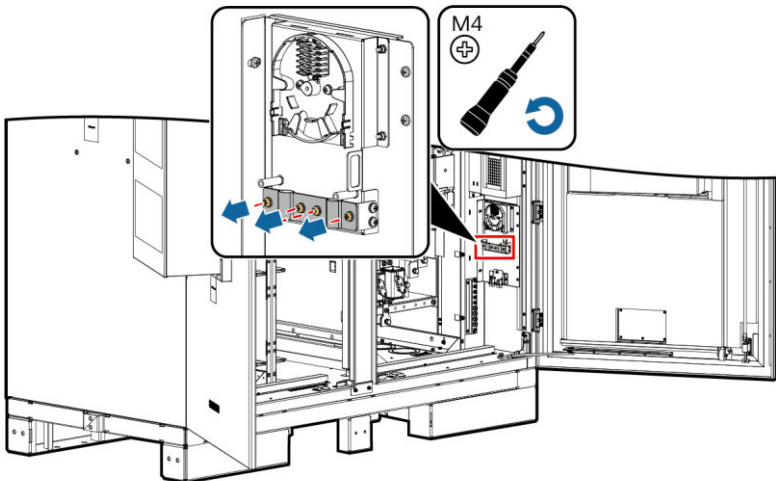

IB03H00007

3. Connect one end of the optical jumper to the fiber adapter.
4. Route the other end of the optical jumper through the cable hole on the side of the ATB, and connect the cable to the ATB.

5. Connect the peripheral optical fiber cable to the ATB, splice the optical fiber cable and the optical jumper, and then wind the spliced cable around the fiber spool on the ATB.
6. Check that the cables are connected correctly and securely. Then reinstall the optical fiber cable fastener and external mechanical parts.

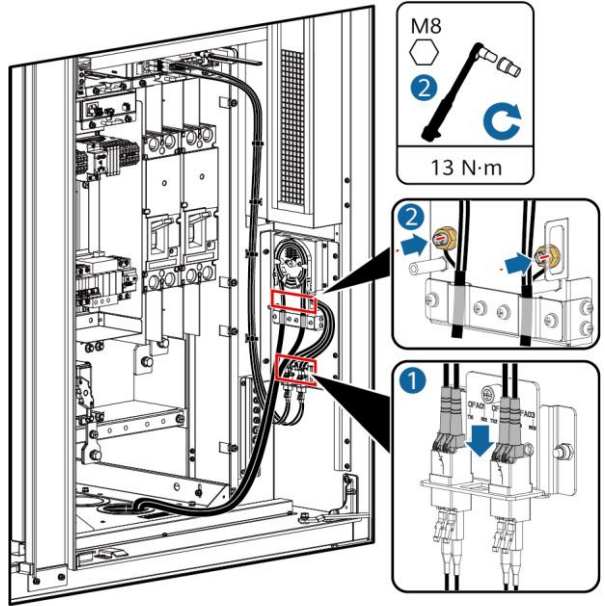

IB03140002

6.9 (Optional) Installing DDSU666-H Cables

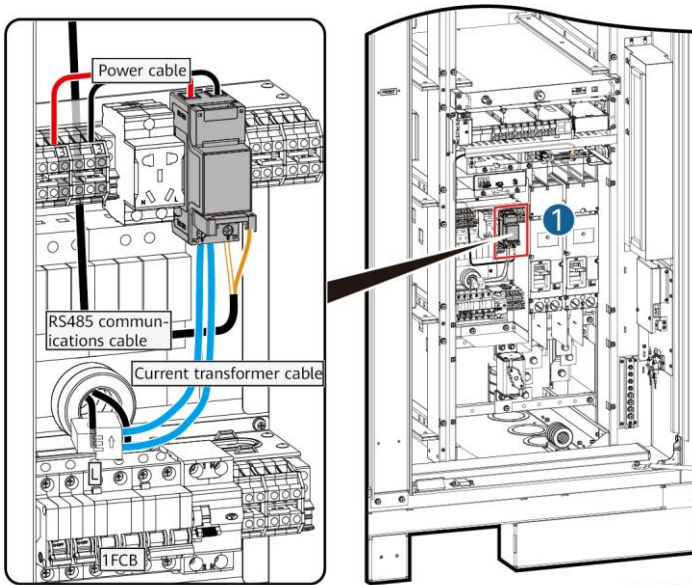

IB0310003

NOTE

If the ESS is connected to an external UPS, the connection method is the same. However, in this scenario, the DDSU666-H cannot measure the power consumption of the 12 V adapter and there is a maximum error of 0.024 kWh per hour.

Name	DDSU666-H Side	ESS Side
RS485 communications cable	485A	K1-COM1:+>1PGH1:485A (preinstalled before delivery)
	485B	K1-COM1:->1PGH1:485B (preinstalled before delivery)
Current transformer cable	CT:5 I* (white) CT:6 I (blue)	XT1:1:2>1FCB:1
Power cable	L	XT1:3:1>1PGH1:L
	N	XT2:3:1>1PGH1:N

6.10 (Optional) Installing Maintenance Socket Cables

NOTE

The actual appearance of the maintenance socket may vary. The figure shows only the installation method.

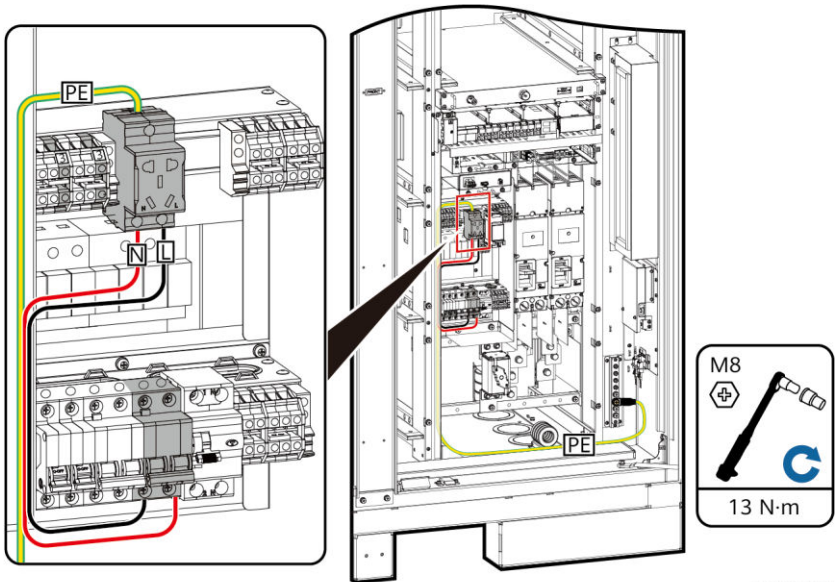

IB03110007

6.11 Sealing Cable Holes

After cables are installed, seal the cable holes using the delivered sealing putty.

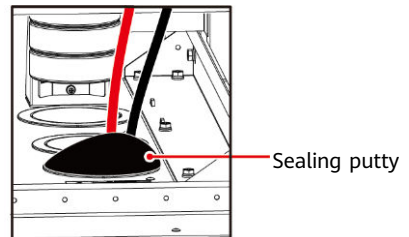

IB03W00018

7 Check Before Power-On

No.	Check Item	Expected Result
1	Equipment appearance	<ul style="list-style-type: none">The equipment is intact and free from rust or paint flake-off. If the paint flakes off, repair the damaged paint.The labels on the equipment are clear. Damaged labels must be replaced.
2	Cable appearance	<ul style="list-style-type: none">Cable sheathings are properly wrapped and not damaged.Cable hoses are intact.
3	Cable connection	<ul style="list-style-type: none">Cables are connected in the designed positions.Terminals are prepared as required and securely connected.Labels on both ends of each cable are clear and specific, and attached in the same direction.
4	Cable routing	<ul style="list-style-type: none">Electrical and ELV cables are routed separately.Cables are neat and tidy.Cable tie joints are evenly cut without burrs.Cables are placed properly and with slack at bending points to avoid stress.Cables are routed neatly without twists or crossovers in the cabinet.
5	Battery pack copper bar	The copper bar is not deformed, and the plastic dip coating is not damaged.
6	Switch	<ul style="list-style-type: none">The DC LV Panel switch is set to OFF.The battery rack switch is set to OFF.

8 System Power-On

8.1 Installing the PSU

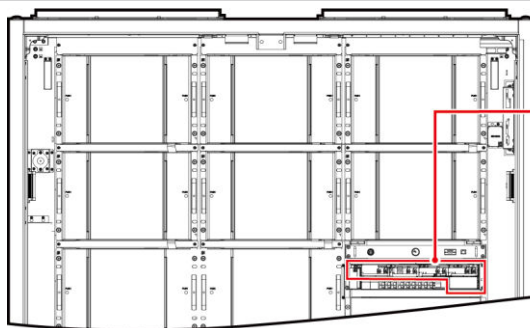

IB03W00025

1. Push the locking latch leftward.
2. Pull out the handle.
3. Gently push the PSU into its slot along the guide rails.
4. Push the handle upward.
5. Push the locking latch rightward to lock the handle.

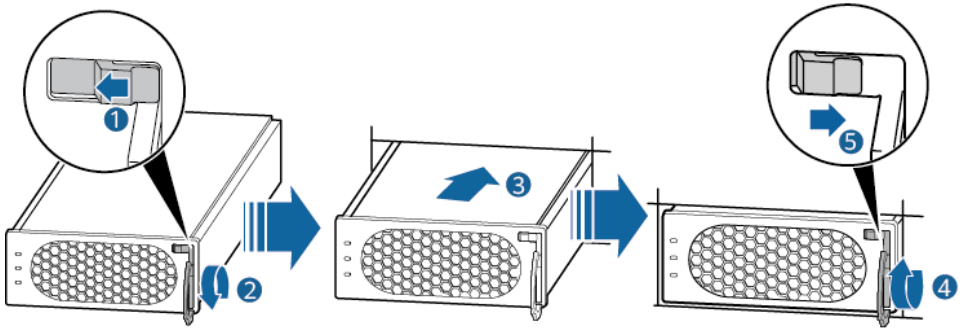

PO01HC0014

8.2 Powering On the ESS

NOTICE

If the ESS has not been used for six months or longer after being installed, it must be checked and tested by professionals before operation.

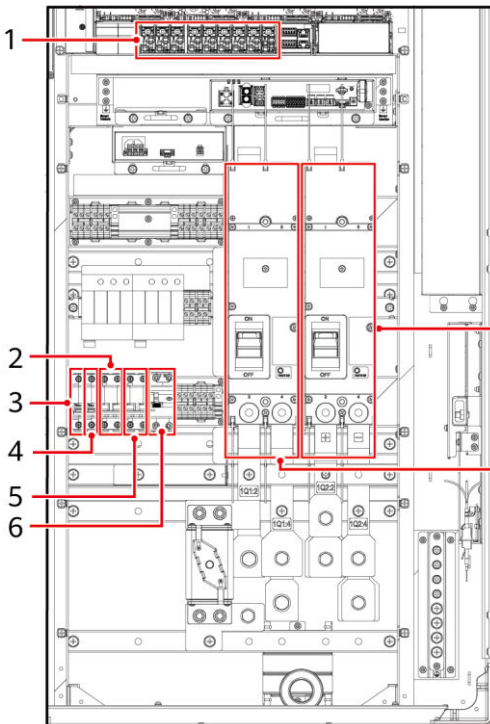

IB03W00045

1. Turn on the DC circuit breaker 1Q1 (as shown by 7 in the figure).
2. Check that the AC voltage is within the allowed range ($220\text{ V} \pm 10\%$) using a multimeter (as shown by 2 in the figure).
3. (Optional) Turn on the UPS cable inlet switch 5FCB (as shown by 5 in the figure).
4. Turn on the AC power distribution switch 1FCB (as shown by 2 in the figure).
5. Turn on all switches in the power distribution system of the ESS.
 - a. Turn on the 12 V adapter switch 1FCB1 (as shown by 3 in the figure).
 - b. Turn on the PSU switch 1FCB2 (as shown by 4 in the figure).
 - c. (Optional) Turn on the maintenance socket switch 1FB1 (as shown by 6 in the figure).
 - d. On the embedded power subrack (SK1), turn on the DC/DC switch 2FCB1, light switch 2FCB2, TCUE switch 2FCB3, fan 1 switch 2FCB6, fan 2 switch 2FCB7, left air conditioner switch 2FCB8, and right air conditioner switch 2FCB9 in sequence (as shown by 1 in the figure).

6. Turn on the DC circuit breaker 1Q2 (as shown by 8 in the figure).

NOTE

Use a multimeter to check that the output voltage at position 1 in the figure is $53\text{ V} \pm 5\text{ V}$.

9 Commissioning (SmartLogger WebUI)

NOTE

- The operating system of Windows 7 or later is supported.
- The web software version corresponding to the WebUI screenshots in this guide is SmartLogger V300R023C00SPC153. The screenshots are for reference only.
- For details about deployment commissioning in energy storage scenarios, see the *Commercial and Industrial Microgrid Energy Storage Solution Quick Guide*.

9.1 Preparations and WebUI Login

1. Connect the network cable between the PC network port and the SmartLogger.
2. Set the IP address of the PC. Ensure that the IP address is in the same subnet as that of the SmartLogger.

Port	IP Setting	Default Value on SmartLogger	Example PC Setting
SmartLogger WAN port	IP address	192.168.0.10	192.168.0.11
	Subnet mask	255.255.255.0	255.255.255.0
	Default gateway	192.168.0.1	192.168.0.1
SmartLogger LAN port	IP address	192.168.8.10	192.168.8.11
	Subnet mask	255.255.255.0	255.255.255.0
	Default gateway	192.168.8.1	192.168.8.1

NOTE

- When the IP address of the WAN port is in the network segment from 192.168.8.1 to 192.168.8.255, set the default gateway to 192.168.8.1 and the IP address of the LAN port to 192.168.3.10. If the connected port is a LAN port, you need to adjust the network configuration of the PC.
- It is recommended that the PC be connected to the LAN port of the SmartLogger or the GE port of the SmartModule. When the PC is connected to the GE port of the SmartModule, adjust the network configuration of the PC in the same way as when the PC is connected to the LAN port of the SmartLogger.

3. Set LAN parameters.

NOTICE

- If the SmartLogger is connected to a LAN and a proxy server has been configured, you need to disable the proxy service.
- If the SmartLogger is connected to the Internet and the PC is connected to the LAN, do not disable the proxy service.

- a. Open Internet Explorer.
- b. Choose **Tools > Internet Options**.
- c. Click the **Connections** tab and click **LAN Settings**.
- d. Clear **Use a proxy server for your LAN**.
- e. Click **OK**.

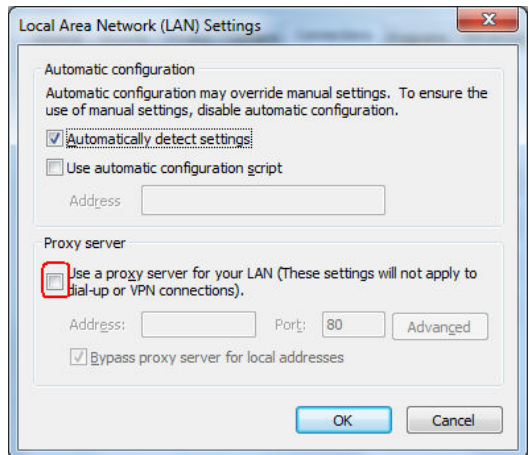

4. Enter **https://XX.XX.XX.XX** (IP address of the SmartLogger) in the address box of your browser. If you log in to the WebUI for the first time, a security risk warning is displayed. Click **Continue to this website**.
5. Log in to the WebUI.

Scenario 1: Initial Login When the User Name Is Displayed as Admin

 **NOTE**

In this scenario, you need to update the SmartLogger to V300R023C00SPC120 or later.

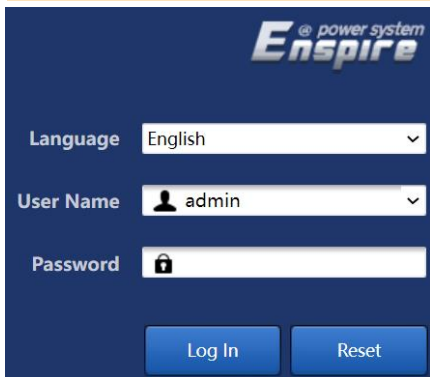

Parameter	Description
Language	Select a desired language.
User Name	The default value is admin .
Password	<ul style="list-style-type: none"> The initial password is Changeme. Use the initial password upon the first power-on and change it immediately after login. Then, use the new password to log in again.

 **NOTE**

For SmartLogger V300R023C00SPC120 or later versions:

- Method 1: Enter **admin** in **User Name** and log in using your new password.
- Method 2: Select **installer** from the drop-down box of **User Name** and log in using your app login password (the initial password is **00000a**).

Scenario 2: Initial Login When the User Name Is Empty



 **NOTE**

In this scenario, the SmartLogger software version is V300R023C00SPC120 or later.

Parameter	Description
Language	Select a desired language.
User Name	Select installer .
Password	Set the login password as prompted.

 **NOTE**

- Protect the password by changing it periodically, and keep it secure. Your password might be stolen or cracked if it is left unchanged for extended periods. If you lose the password, the device must be restored to its factory settings. In these cases, the Company shall not be liable for any loss caused to the plant.
- You will be locked out for 10 minutes after five failed password attempts in 5 minutes.
- A dialog box with recent login information is displayed after login. Click **OK**.

9.2 Checking the SmartLogger Software Version

Choose **Monitoring > Logger(Local) > About** and check that the software version is the same as the latest version in **FusionSolar Software Download** (<https://support.huawei.com/enterprise/en/fusionsolar/smartlogger-pid-21294677/software>).

No.	Signal Name	Value	Unit
1	SN	xxxxxxxxxxxxxxxx	
2	Software version	Smartlogger V300R023C00SPC153	
3	Hardware Version	C	

9.3 Upgrading the SmartLogger

NOTE

- If the SmartLogger software version is not the latest version in **FusionSolar Software Download**, upgrade the SmartLogger.
- Obtain the SmartLogger upgrade package from the Company.

1. Choose **Maintenance > Software Upgrade**, upload the SmartLogger upgrade package, select the target device, and upgrade the SmartLogger.

2. After the software upgrade is complete, the SmartLogger automatically restarts. Log in to the SmartLogger WebUI again 2 minutes later.

9.4 Upgrading the ESS

1. Choose **Monitoring > ESU > Running Info.**, click  in the upper right corner to complete the reset operation, and wait for 2 minutes.

No.	Signal Name	Value	Unit
1	Battery type	Huawei	
2	Quantity of working battery packs	0	
3	Chargeable capacity	0.000	kWh
4	Dischargeable capacity	0.000	kWh
5	Rated charge capacity	0.000	kWh

- Choose **Monitoring** > **ESR**, click +, and check that all ESM status indicators under the ESR are green or yellow.

NOTE

The quantity of ESMs displayed must be the same as the actual quantity of installed battery packs.

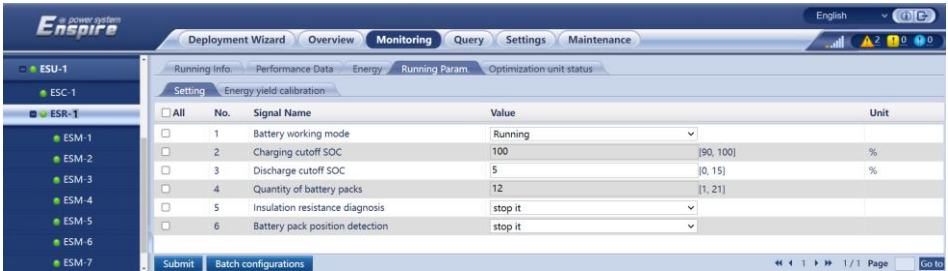

- Choose **Monitoring** > **ESR** > **Running Param.** > **Setting** and set **Quantity of battery packs** to the actual quantity of installed battery packs.

ESS	Quantity of Battery Packs
LUNA2000-97KWH-1H1	6
LUNA2000-129KWH-2H1	8
LUNA2000-161KWH-2H1	10
LUNA2000-200KWH-2H1	12

- Choose **Monitoring** > **ESM** > **About** and check all ESM software versions.

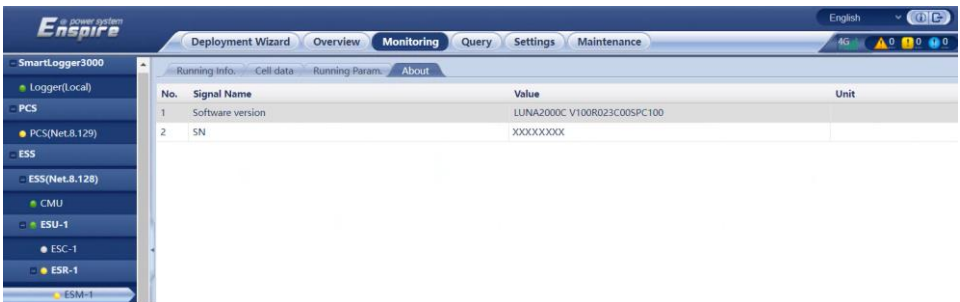

NOTE

- If the software version of an ESM is not the latest version in **FusionSolar Software Download** (<https://support.huawei.com/enterprise/en/fusionsolar/luna2000b-pid-255740921/software>), upgrade the ESS and ensure that the ESM software version matches the SmartLogger software version.
- If an alarm **Version Inconsistent Between Rack Controller and Battery Packs** or **Version Incompatible Between Rack Controller and Battery Packs** is generated, upgrade the ESS.
- Obtain the upgrade package from the Company.

- Choose **Maintenance > Software Upgrade**, upload the upgrade package, select the CMU, CMU_BSP, and ESU, and upgrade the software.

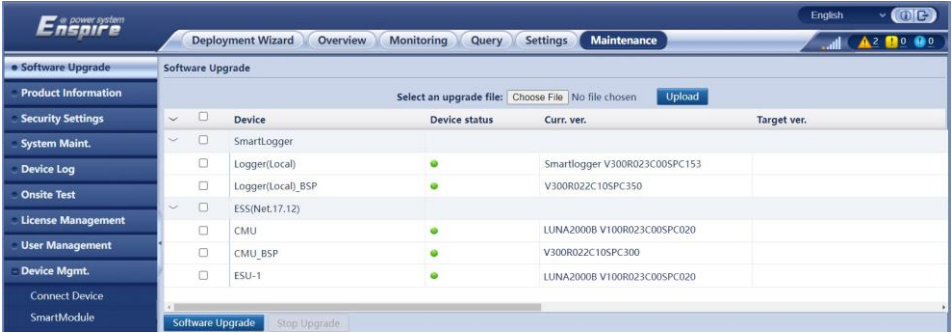

- Choose **Monitoring > ESM** and check  in the upper right corner to ensure that no major alarm is generated.

9.5 System Startup

NOTE

Start up the system when needed.

- On the SmartLogger WebUI, choose **Maintenance > Device Mgmt. > Connect Device**.
- Click  in the upper right corner to start devices in batches.

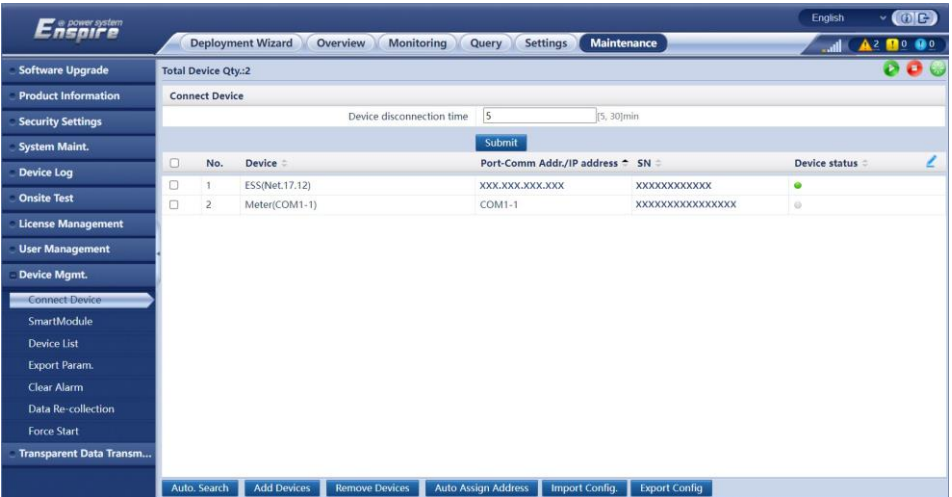

9.6 Setting Capacity Limit

Choose **Settings > Battery Control > Capacity Limit** to set the capacity limit.



Parameter	Description
No control	If this parameter is set, the capacity of the grid-connection point is not limited. The inverter and Smart PCS run according to the preset control policy.
Active capacity limit	If this parameter is set, the active power of the grid-connection point for purchasing or feeding power cannot exceed the preset capacity limit.
Apparent capacity limit	If this parameter is set, the apparent power of the grid-connection point for purchasing or feeding power cannot exceed the preset capacity limit.

10 Closing the Cabinet Doors

After the deployment commissioning is complete, close the cabinet doors and secure the safety rope.

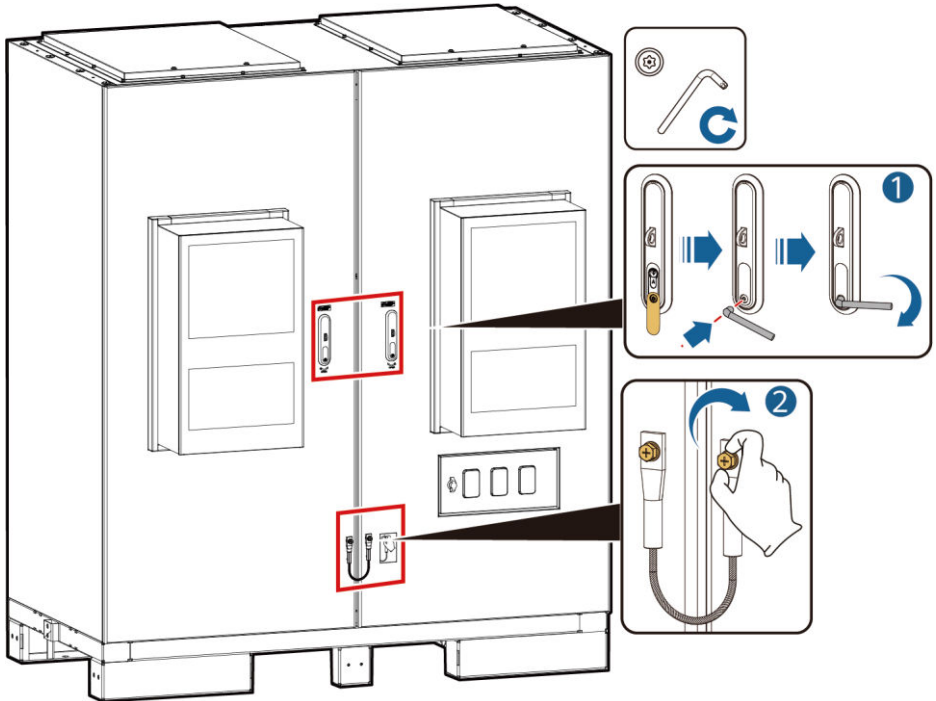

11 FAQ

11.1 How Do I Connect the ESS to the FusionSolar Smart PV Management System?

1. Enter `https://management system IP address: 31943` in the address box of a browser, and press **Enter**. The login page is displayed.
2. Enter the username or email address and password, and click **Log In**.

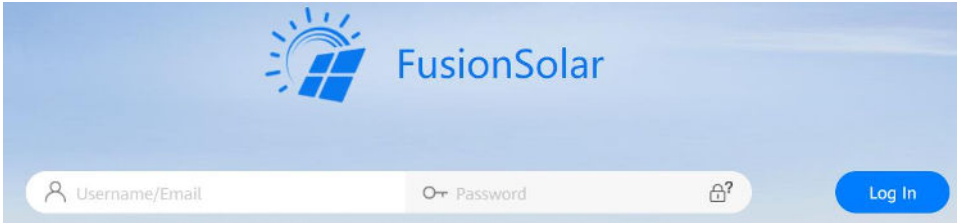

11.2 How Do I Create a Plant?

1. Choose **Configuration > Plant Management** from the main menu.
2. On the **Plant Management** page, click **Add Plant**.

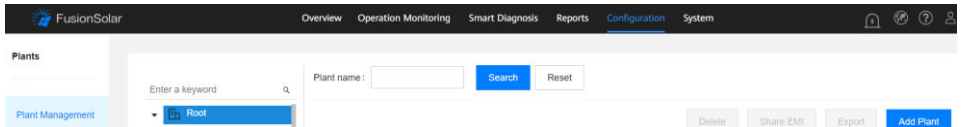

3. Perform the steps as prompted.

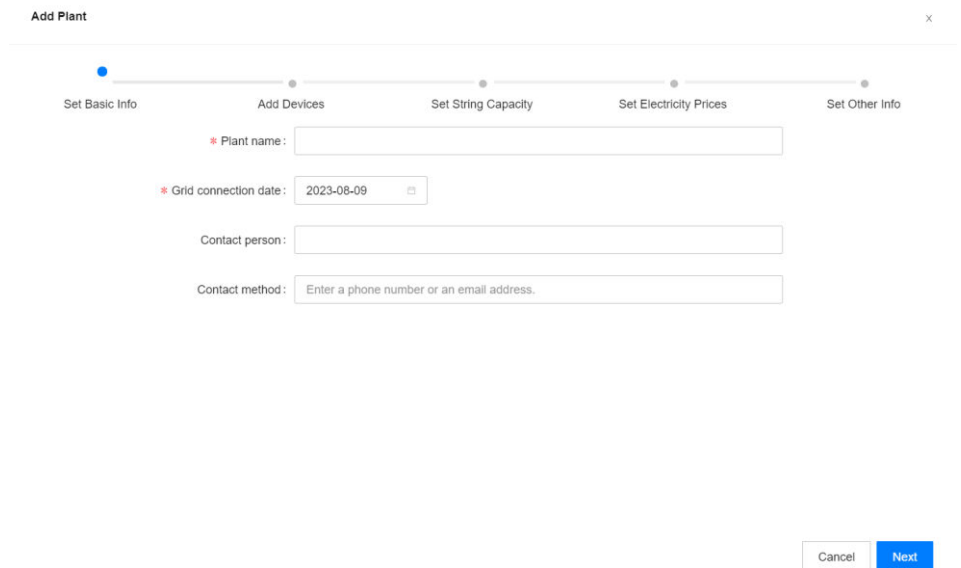

12 Contact Information



<https://digitalpower.huawei.com>

Path: **About Us** > **Contact Us** > **Service Hotlines**

13 Digital Power Customer Service



<https://digitalpower.huawei.com/robotchat/>

Huawei Digital Power Technologies Co., Ltd.

Huawei Digital Power Antuoshan Headquarters

Futian, Shenzhen 518043

People's Republic of China

<https://digitalpower.huawei.com>